

User's and Programming Guide
Agilent Technologies
ESG Family Signal Generators
Option 100 - Volume 2
W-CDMA (3GPP V3.5 2001-03) Personality

Serial Number Prefixes:

(Affix Label Here)



Part No. E4400-90329

Printed in USA

April 2002

Supersedes **June 2001**

© Copyright 1999-2002 Agilent Technologies

1. The W-CDMA (3GPP 3.5 2001-03) Personality

| | |
|---|-----|
| Ensure you have the correct guide | 1-2 |
| Overview | 1-3 |
| Revision Numbers | 1-3 |
| Block Diagrams | 1-3 |

2. Using Functions

| | |
|--|------|
| Table Editor Basics | 2-2 |
| Using W-CDMA (3GPP 3.5 2001-03) | 2-3 |
| Accessing the W-CDMA Menu | 2-3 |
| Selecting Predefined Channel Configurations | 2-4 |
| Downlink Predefined Channel Configurations | 2-4 |
| Uplink Predefined Channel Configurations | 2-4 |
| Selecting a Downlink Predefined Channel Configuration | 2-5 |
| Selecting an Uplink Predefined Channel Configuration | 2-6 |
| Modifying Downlink Channel Configurations | 2-8 |
| Inserting Additional Channels | 2-8 |
| Editing Downlink Channel Values in the Table Editor | 2-11 |
| Modifying Uplink Channel Configurations | 2-14 |
| Inserting Additional Channels | 2-14 |
| Editing Uplink Channel Values in the Table Editor | 2-17 |
| Storing a Custom W-CDMA State to Memory | 2-20 |
| Creating, Storing, & Recalling a Custom Multicarrier W-CDMA Waveform | 2-22 |
| Opening the Multicarrier W-CDMA Setup Table Editor | 2-22 |
| Modifying a Multicarrier W-CDMA 4-Carrier Template | 2-23 |
| Activating a Custom Multicarrier W-CDMA Setup | 2-24 |
| Storing a Custom Multicarrier W-CDMA Waveform | 2-25 |
| Recalling a Custom Multicarrier W-CDMA Waveform | 2-25 |
| Identifying and Resolving Code Domain Conflicts | 2-26 |
| Identifying Conflicts | 2-26 |
| Resolving Conflicts | 2-27 |
| Outputting a W-CDMA Waveform | 2-28 |
| Setting the Carrier Frequency and Power | 2-28 |
| Generating the W-CDMA Waveform and Enabling the RF Output | 2-29 |
| Clipping the W-CDMA Waveform | 2-29 |
| Creating a User-Defined FIR Filter Using the FIR Table Editor | 2-31 |
| Accessing the Table Editor | 2-31 |
| Entering the Coefficient Values | 2-32 |
| Duplicating the First 16 Coefficients Using Mirror Table | 2-33 |
| Setting the Oversample Ratio | 2-33 |
| Displaying a Graphical Representation of the Filter | 2-34 |
| Storing the Filter to Memory | 2-35 |
| Modifying an FIR Filter Using the FIR Table Editor | 2-36 |
| Loading the Default Gaussian FIR File | 2-36 |
| Modifying the Coefficients | 2-37 |
| Storing the Filter to Memory | 2-38 |
| Applying a User-Defined FIR Filter to a W-CDMA Waveform | 2-39 |

3. Softkey Reference

| | |
|-----------------------------|------|
| Mode Key | 3-2 |
| <i>n</i> ksps | 3-3 |
| 1 DPCH | 3-3 |
| 2 | 3-3 |
| 2 Carriers | 3-4 |
| 2.500 MHz | 3-4 |
| 3 Carriers | 3-4 |
| 3 DPCH | 3-4 |
| 4 | 3-5 |
| 4 Carriers | 3-5 |
| 8 | 3-5 |
| 8.000 MHz | 3-5 |
| 250 kHz | 3-6 |
| Adjust Code Domain Power | 3-6 |
| APCO 25 C4FM | 3-6 |
| Apply Channel Setup | 3-6 |
| Apply Multicarrier | 3-6 |
| Apply To Waveform | 3-7 |
| ARB Reference Ext Int. | 3-7 |
| Beta | 3-7 |
| Bus | 3-7 |
| Channels | 3-8 |
| Chip Rate | 3-8 |
| Clip I+jQ To | 3-8 |
| Clip I To | 3-9 |
| Clip Q To | 3-9 |
| Clip At PRE POST FIR Filter | 3-9 |
| Clipping | 3-9 |
| Clipping Type I+jQ I , Q | 3-10 |
| Continuous | 3-10 |
| CPICH | 3-10 |
| Custom W-CDMA Carrier | 3-10 |
| Custom W-CDMA Multicarrier | 3-10 |
| Custom W-CDMA State | 3-11 |
| Define User FIR | 3-11 |
| Delete All Rows | 3-11 |
| Delete File | 3-11 |
| Delete Row | 3-11 |
| Display Code Domain Power | 3-12 |
| Display FFT | 3-13 |
| Display Impulse Response | 3-14 |
| DPCCH | 3-14 |
| DPCCH + 1 DPDCH | 3-14 |
| DPCCH + 2 DPDCH | 3-14 |
| DPCCH + 3 DPDCH | 3-15 |
| DPCCH + 4 DPDCH | 3-15 |
| DPCCH + 5 DPDCH | 3-15 |
| DPCH | 3-15 |

Contents

| | |
|---------------------------|------|
| Edit Channel Setup | 3-15 |
| Edit Item | 3-16 |
| Equal Energy per Symbol | 3-16 |
| Ext | 3-16 |
| Ext Delay Off On | 3-16 |
| Ext Delay Time | 3-16 |
| Ext Polarity Neg Pos | 3-17 |
| Filter | 3-17 |
| Filter Alpha | 3-17 |
| Filter BbT | 3-18 |
| Filter Factor | 3-18 |
| Filter Symbols | 3-19 |
| First Spread Code | 3-19 |
| Gain Unit dB Lin Index | 3-20 |
| Gate Active | 3-20 |
| Gated | 3-20 |
| Gaussian | 3-20 |
| Goto Bottom Row | 3-21 |
| Goto Middle Row | 3-21 |
| Goto Row | 3-21 |
| Goto Top Row | 3-21 |
| Hamming | 3-21 |
| Hann | 3-22 |
| I/Q Mapping Normal Invert | 3-22 |
| Insert DPDCH | 3-22 |
| Insert Row | 3-22 |
| IS-2000 SR3 DS | 3-23 |
| IS-95 | 3-23 |
| IS-95 and IS-2000 | 3-23 |
| IS-95 Mod | 3-23 |
| IS-95 Mod w/EQ | 3-23 |
| IS-95 w/EQ | 3-23 |
| Kaiser | 3-24 |
| Left Alternate | 3-24 |
| Link Down Up | 3-24 |
| Load Default FIR | 3-24 |
| Load From Selected File | 3-25 |
| Load/Store | 3-25 |
| Mirror Table | 3-25 |
| Modify All Scramble Codes | 3-25 |
| Multicarrier Define | 3-25 |
| Multicarrier Off On | 3-26 |
| Multiple Channels | 3-26 |
| Next Scramble Code | 3-26 |
| None | 3-26 |
| Nyquist | 3-27 |
| OCNS | 3-27 |
| Optimize FIR For EVM ACP | 3-27 |
| Oversample Ratio | 3-28 |

Contents

| | |
|---------------------------|------|
| Page Down | 3-28 |
| Page Up | 3-28 |
| PCCPCH | 3-28 |
| PCCPCH + SCH | 3-28 |
| PCCPCH + SCH + 1 DPCH | 3-28 |
| PCCPCH + SCH + 3 DPCH | 3-29 |
| PICH | 3-29 |
| Plot CCDF | 3-29 |
| PN9 | 3-29 |
| Power | 3-30 |
| Previous Scramble Code | 3-30 |
| Primary Key | 3-30 |
| PSCH | 3-30 |
| Random | 3-31 |
| Rate | 3-31 |
| Reconstruction Filter | 3-31 |
| Rectangle | 3-31 |
| Reference Frequency | 3-32 |
| Reset Table | 3-32 |
| Restore Default Filter | 3-32 |
| Retrigger Mode Off On | 3-32 |
| Right Alternate | 3-32 |
| Root Nyquist | 3-33 |
| Scale To 0dB | 3-33 |
| SCCPCH | 3-33 |
| Scramble | 3-34 |
| Scramble Code | 3-34 |
| Scramble Offset | 3-35 |
| Scramble Type | 3-35 |
| Second DPDCH I Q | 3-36 |
| Secondary Key | 3-36 |
| Select | 3-36 |
| Single | 3-37 |
| Select File | 3-37 |
| Sort | 3-37 |
| Sort Table | 3-37 |
| Spread Code | 3-37 |
| SSCH | 3-37 |
| Standard | 3-38 |
| Store Custom Multicarrier | 3-38 |
| Store Custom W-CDMA State | 3-38 |
| Store To File | 3-39 |
| Symbol Rate | 3-39 |
| Test Models | 3-40 |
| Test Model 1 W/ 16 DPCH | 3-40 |
| Test Model 1 W/ 32 DPCH | 3-40 |
| Test Model 1 W/ 64 DPCH | 3-40 |
| Test Model 2 | 3-41 |
| Test Model 3 W/ 16 DPCH | 3-41 |

Contents

| | |
|---|------|
| Test Model 3 W/ 32 DPCH | 3-41 |
| Test Model 4 | 3-41 |
| TFCI Field Off On | 3-42 |
| Through | 3-42 |
| Trigger | 3-42 |
| Trigger Key | 3-42 |
| Trigger Setup | 3-42 |
| Trigger Source | 3-43 |
| Type | 3-43 |
| UN3/4 GSM Gaussian | 3-43 |
| User FIR | 3-43 |
| View Next Page | 3-44 |
| Waveform Statistics | 3-44 |
| WCDMA | 3-44 |
| W-CDMA (3GPP 3.5 200103) | 3-44 |
| W-CDMA Define | 3-44 |
| W-CDMA Off On | 3-45 |
| W-CDMA Select | 3-45 |
| Window | 3-46 |
| | |
| 4. Operation | |
| W-CDMA Frame Structures | 4-2 |
| Downlink PICH Frame Structure | 4-2 |
| Downlink PCCPCH + SCH Frame Structure | 4-3 |
| Downlink DPDCH/DPCCCH Frame Structure | 4-4 |
| Uplink DPDCH/DPCCCH Frame Structure | 4-5 |
| Understanding TPC Values | 4-6 |
| Understanding TFCI, TPC, and Pilot Power Offsets | 4-7 |
| Understanding Baseband Clipping | 4-9 |
| How Power Peaks Develop | 4-9 |
| How Peaks Cause Spectral Regrowth | 4-11 |
| How Clipping Reduces Peak-to-Average Power | 4-12 |
| FIR Filtering Options | 4-14 |
| How Clipping Differs from Symbol Offset | 4-15 |
| Calculating Downlink Scramble Codes | 4-16 |
| Scramble Codes with Standard Scramble Type | 4-17 |
| Scramble Codes with Right and Left Alternate Scramble Types | 4-18 |
| | |
| 5. Remote Programming | |
| W-CDMA Subsystem SCPI Command Reference | 5-2 |
| Apply Waveform | 5-2 |
| ARB Reference Internal External | 5-2 |
| Channel Setup | 5-2 |
| Chip Rate | 5-5 |
| Clipping Level, $ I+jQ $ | 5-5 |
| Clipping Level, $ I $ | 5-5 |
| Clipping Level, $ Q $ | 5-5 |
| Clipping, Pre/Post FIR Filter | 5-5 |

| | |
|--|------|
| Clipping, Type | 5-6 |
| Code Domain Power | 5-6 |
| External Trigger Delay State | 5-6 |
| External Trigger Delay Time | 5-6 |
| External Trigger Polarity | 5-7 |
| Filter Alpha | 5-7 |
| Filter BbT | 5-7 |
| Filter Optimization | 5-7 |
| Filter Selection | 5-8 |
| Gain Unit | 5-8 |
| Gate Active | 5-9 |
| I/Q Mapping | 5-9 |
| Link Direction | 5-9 |
| Multicarrier, Define | 5-9 |
| Multicarrier, Select Setup | 5-10 |
| Multicarrier, Store Custom | 5-11 |
| Reconstruction Filter | 5-11 |
| Reference Frequency | 5-11 |
| Retrigger Mode State | 5-11 |
| Revision Query | 5-12 |
| Scramble Code | 5-12 |
| Second DPDCH Setup | 5-12 |
| TFCI Field State | 5-12 |
| Trigger Source | 5-12 |
| Trigger Type | 5-13 |
| User FIR Definition | 5-13 |
| W-CDMA Link Setup | 5-13 |
| W-CDMA State, On/Off | 5-14 |
| W-CDMA State, Store Custom | 5-15 |

6. Programming Command Cross-Reference

1 The W-CDMA (3GPP 3.5 2001-03) Personality

This guide provides information specific to the Option 100 W-CDMA (3GPP 3.5 2001-03) personality. This chapter contains an overview of Option 100.

NOTE This option requires the installation of Option UND, Dual Arbitrary Waveform Generator. Refer to the Option UND user's and programming guide for information.

Ensure you have the correct guide

The Option 100 ESG Family Signal Generator includes two different implementations of the W-CDMA personality. Therefore, two user's and programming guides (one for each implementation) are supplied for Option 100. Read the following descriptions to ensure you have the correct guide for the W-CDMA personality you require.

Volume 1 contains information specific to the W-CDMA (Rev. 1.0-1.2) personality, which is based on the March 1999 ARIB 1.0-1.2 specification.

Volume 2 (this guide) contains information specific to the W-CDMA (3GPP 3.5 2001-03) personality, which implements a chip rate of 3.84 Mcps, and is based on the March 2001 3GPP 3.5 specification.

Overview

The Option 100 ESG Family Signal Generator is a multichannel, wideband code division multiple access (W-CDMA) stimulus intended for base station and mobile testing. Option 100 enables you to generate downlink and uplink signals consistent with the developing W-CDMA (3GPP 3.5 2001-03) system specifications. You can create user-defined custom signals using a simple table-based channel editor.

Option 100 includes:

- multichannel W-CDMA downlink or uplink signals
- multicarrier (up to 4) W-CDMA downlink signals
- OCQPSK (HPSK) spreading/modulation type used in uplink
- baseband clipping: clip the composite I/Q waveform or I and Q separately; choose either pre- or post-FIR filter clipping
- control over power level of TFCI, TPC, FBI, and pilot symbols relative to data
- transmitted chip rate of 3.84 Mcps (variable to $\pm 10\%$)
- select from predefined W-CDMA channels, including 3GPP-defined test models, or use the table editor to fully configure a W-CDMA signal waveform per your requirements

NOTE Specifications for Option 100 are located in the technical specifications document.

Revision Numbers

The firmware personality of the Option 100 signal generator is based on continually developing W-CDMA international standards. Therefore, the firmware is upgraded periodically to stay current with these standards. For identification purposes, a revision number is assigned to each release of the Option 100 personality. The revision number appears in softkey menus, status displays, and this guide. This guide describes the features associated with the Option 100 W-CDMA (3GPP 3.5 2001-03) personality.

Block Diagrams

[Figure 1-1](#) on page 1-4 and [Figure 1-2](#) on page 1-5 show the downlink and uplink channel structures supported by Option 100.

Figure 1-1 Option 100 Downlink Channel Structure

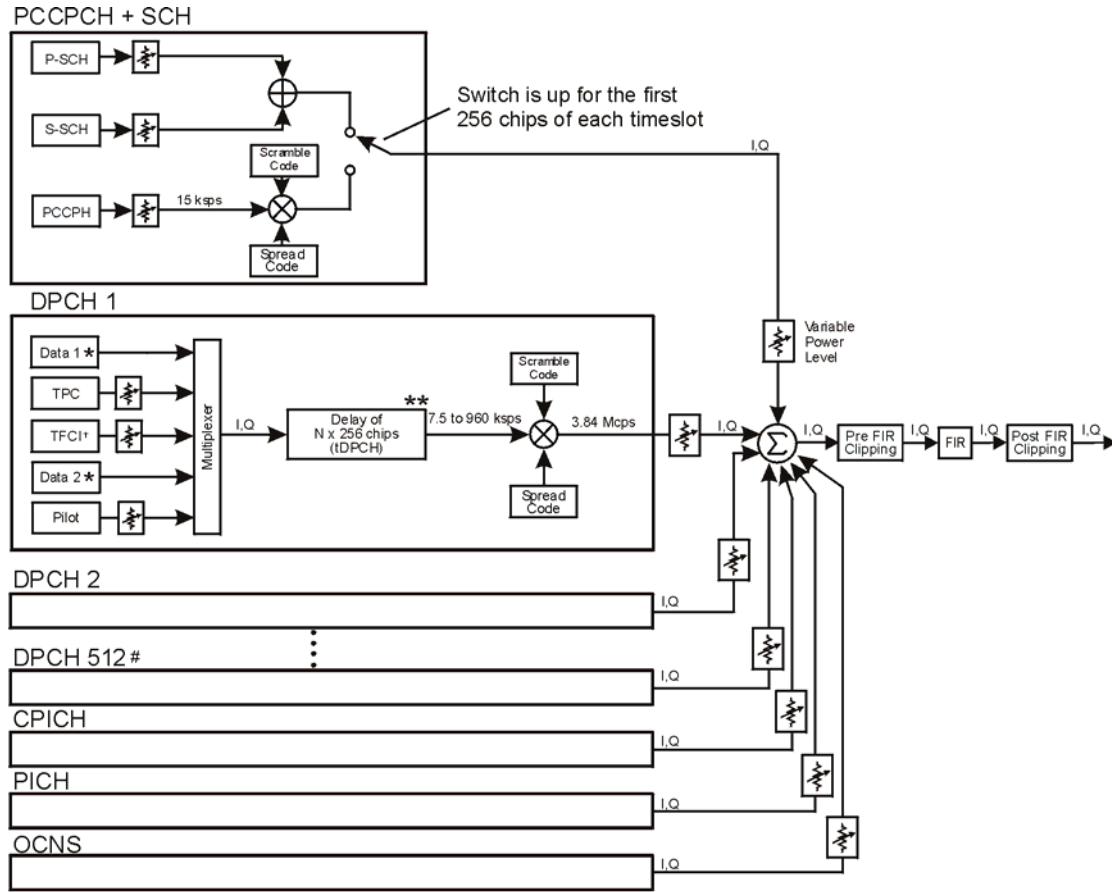

- # Maximum 512 Traffic Channels
- ** Range of symbol offsets depends on the channel symbol rate.
- † Transmission can be configured with or without TFC and variable number of pilot bits.
- * Random data, PN9, or 8-bit repeating pattern

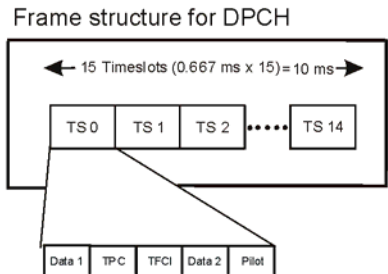

pk756b

Figure 1-2 Option 100 Uplink Channel Structure

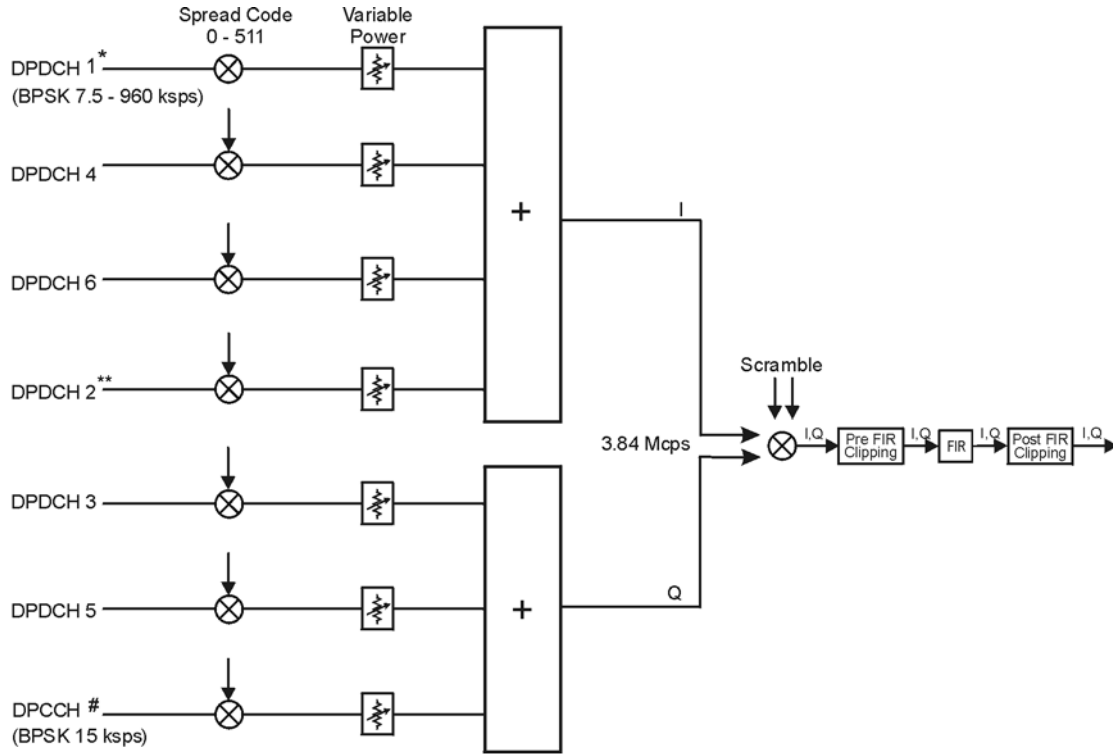

- * User Data: Random, PN9, or 8-bit Repeating Pattern
- # TFC, FBI, & TPC data fields may be edited. TFCI field may be turned off. Variable number of FBI bits.
- ** DPDCH 2 can be set to either I or Q. DPDCH 3 - DPDCH 6 alternate between I and Q accordingly.

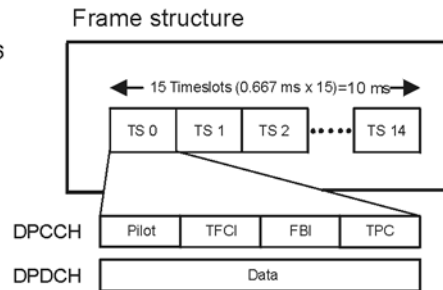

pk757b

2 Using Functions

This chapter contains instructions for using the features associated with the Option 100 W-CDMA (3GPP 3.5 2001-03) personality.

Table Editor Basics

Option 100 provides several table editors that enable you to:

- modify W-CDMA downlink channel configurations (for details, see [page 2-8](#))
- modify W-CDMA uplink channel configurations (for details, see [page 2-14](#))
- create a custom multicarrier waveform (for details, see [page 2-22](#))
- create a user-defined FIR filter (for details, see [page 2-31](#))
- modify a user-defined FIR filter (for details, see [page 2-36](#))

While each of these table editors performs a different function, they are all used in a similar manner, and most of the table editors have several editing softkeys in common.

Common Edit Functions

| | |
|-----------------------------|---|
| Edit Item | Enables you to use the front panel knob and arrow keys to edit the value of a selected entry. After highlighting the value you want to edit, press this softkey. |
| Insert Row | Displays a menu where you can select the type of row you wish to insert above the currently selected row. |
| Delete Row | Deletes the highlighted row in the table. |
| Goto Row | Displays a new page of softkeys so that you can quickly move to the first, middle, or last row of data. This is especially helpful in a large table, or when using the filter table editor mirror function. |
| Load Default FIR | Enables you to reset factory default values for a FIR filter. |
| Load/Store | Displays a new page of softkeys that enables you to load data from a stored file, save data to a file, or delete a stored file. |
| Delete All Rows | Deletes all rows in the current table editor. |

CAUTION Deletions cannot be recovered.

Using W-CDMA (3GPP 3.5 2001-03)

This chapter describes how to set up a waveform using predefined and user-defined channels. You will learn how to perform the following:

- select channels
- modify channels
- activate the modulation and RF output
- use multicarrier waveforms
- identify and resolve code domain conflicts
- create filters
- modify filters

Accessing the W-CDMA Menu

Use the following procedure to access the W-CDMA personality.

1. Press **Preset**.
2. Press **Mode > Arb Waveform Generator** (if it appears).
3. Press **CDMA Formats**.
4. Press **W-CDMA (3GPP 3.5 200103)** to display the W-CDMA menu. The first page of W-CDMA softkeys is displayed on the right side of the display. The center text area of the display shows the status of W-CDMA configuration. These characteristics are immediately updated when you modify them in the softkey menus.



Selecting Predefined Channel Configurations

The Option 100 signal generator contains predefined channel setups for both downlink and uplink waveform generation.

Downlink Predefined Channel Configurations

There are eleven predefined channel configurations for downlink:

- 1 DPCH
- 3 DPCH
- PCCPCH
- PCCPCH + SCH
- PCCPCH + SCH + 1 DPCH
- PCCPCH + SCH + 3 DPCH
- Test Model 1 W/ 16 DPCH
- Test Model 1 W/ 32 DPCH
- Test Model 1 W/ 64 DPCH
- Test Model 2
- Test Model 3 W/ 16 DPCH
- Test Model 3 W/ 32 DPCH

Uplink Predefined Channel Configurations

There are six predefined channel configurations for uplink:

- DPCCH
- DPCCH plus 1 DPDCH
- DPCCH plus 2 DPDCH
- DPCCH plus 3 DPDCH
- DPCCH plus 4 DPDCH
- DPCCH plus 5 DPDCH

The default predefined channel configuration is one dedicated physical channel (1 DPCH) in the downlink mode. Predefined channel configurations can be used as defined, or modified using the channel table editor. See [“Modifying Downlink Channel Configurations”](#) on page 2-8 for more information.

The following procedures explain how to select predefined channel setups for both downlink and uplink waveform configurations.

Selecting a Downlink Predefined Channel Configuration

Use the following procedure to select downlink predefined channel configurations.

1. Press **Preset**.
2. Press **Mode > Arb Waveform Generator** (if it appears).
3. Press **CDMA Formats**.
4. Press **W-CDMA (3GPP 3.5 200103)** to display the W-CDMA menu. The default predefined channel selection for downlink (1 DPCH) appears below **W-CDMA Select** in the softkey menu. The text area displays DL WCDMA Setup: 1 DPCH as the current configuration, as shown in the following figure.



5. Press **W-CDMA Select** to display the W-CDMA Select menu for downlink, as shown in the following figure.



- Press **PCCPCH + SCH** to select a PCCPCH plus SCH downlink channel. (PCCPCH + SCH) appears below **W-CDMA Select** in the softkey menu. The text area displays DL WCDMA Setup: PCCPCH + SCH as the current configuration, as shown in the following figure.



Selecting an Uplink Predefined Channel Configuration

Use the following procedure to select uplink predefined channel configurations.

- Press **Preset**.
- Press **Mode > Arb Waveform Generator** (if it appears).
- Press **CDMA Formats**.
- Press **W-CDMA (3GPP 3.5 200103)** to display the W-CDMA menu.
- Press **Link Down Up**. The default predefined channel selection for uplink (DPCCH) appears below **W-CDMA Select** in the softkey menu. The text area displays UL WCDMA Setup: DPCCH as the current configuration, as shown in the following figure.



6. Press **W-CDMA Select** to display the W-CDMA Select menu for uplink, as shown in the following figure.



7. Press **DPCCH + 3 DPDCH** to select a DPCCH plus three DPDCH channels. (DPCCH + 3 DPDCH) appears below **W-CDMA Select** in the softkey menu. The text area displays UL WCDMA Setup: DPCCH + 3 DPDCH as the current configuration, as shown in the following figure.

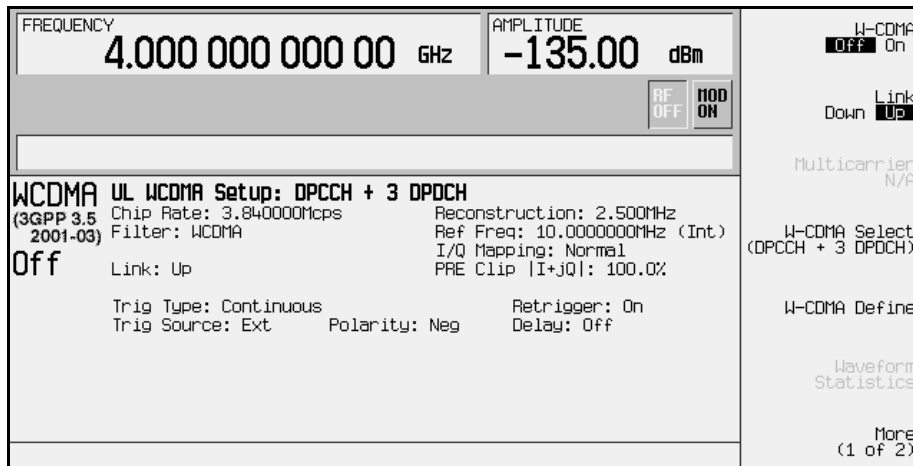

Modifying Downlink Channel Configurations

You can modify downlink channel configurations using the channel setup table editor. The following examples show you how to modify predefined channel setups for downlink waveform configurations. Refer to “[Table Editor Basics](#)” on page 2-2 for additional information about table editors.

CAUTION Unless previously saved to the signal generator’s memory catalog, modifications made to predefined channel configurations are lost when changes are made to link direction.

To store a custom W-CDMA state, see “[Storing a Custom W-CDMA State to Memory](#)” on page 2-20.

Inserting Additional Channels

The default downlink channel setup is one dedicated physical channel (1 DPCH). The maximum number of downlink channels allowed in the channel table editor is 512.

In the following sections, examples are provided for inserting DPCH and PCCPCH + SCH channels into the downlink configuration.

Inserting Additional DPCH Channels

In this example, 20 additional DPCH channels are inserted into the default predefined downlink configuration.

1. Press **Preset**.
2. Press **Mode > Arb Waveform Generator** (if it appears).
3. Press **CDMA Formats**.
4. Press **W-CDMA (3GPP 3.5 200103)** to display the W-CDMA menu.
5. Press **W-CDMA Define > Edit Channel Setup** to display the channel table editor, as shown in the following figure. The horizontal scroll bar at the bottom of the screen indicates that there are more columns to the right of the Scramble Code column. Use the right arrow key to move the cursor to view the additional columns.

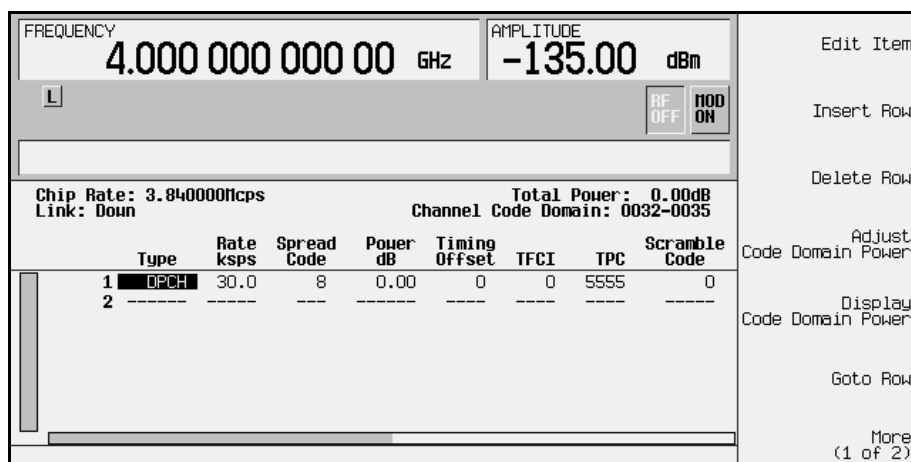

6. Press **Insert Row > More (1 of 2) > Multiple Channels > Channels** and enter 20. Terminate the entry with the **Enter** softkey.
7. Press **Done**. The channel table editor now contains the 20 additional channels, as shown in the following figure. The page only displays six channels. To see the additional channels, press **Return > Goto Row > Page Up**.

| FREQUENCY | | 4.000 000 000 00 GHz | | AMPLITUDE | | -135.00 dBm | | PICH |
|-------------------------|-----------|----------------------|----------|----------------------|-------|--------------------------------|---------------|-------------------|
| I | | | | RF OFF | | MOD ON | | OCNS |
| Chip Rate: 3.840000Mcps | | Link: Down | | Total Power: 13.22dB | | Channel Code Domain: 0032-0035 | | Multiple Channels |
| Type | Rate ksps | Spread Code | Power dB | Timing Offset | TFCI | TPC | Scramble Code | |
| 17 | DPCH | 30.0 | 25 | 0.00 | 6 | 0 | 5555 | 0 |
| 18 | DPCH | 30.0 | 26 | 0.00 | 12 | 0 | 5555 | 0 |
| 19 | DPCH | 30.0 | 27 | 0.00 | 8 | 0 | 5555 | 0 |
| 20 | DPCH | 30.0 | 28 | 0.00 | 10 | 0 | 5555 | 0 |
| 21 | DPCH | 30.0 | 8 | 0.00 | 0 | 0 | 5555 | 0 |
| 22 | ----- | ----- | ----- | ----- | ----- | ----- | ----- | ----- |
| | | | | | | | | More (2 of 2) |

8. Press **Return** until the status screen appears. The text area displays DL WCDMA Setup:1 DPCH (Modified) as the current configuration.

To store a custom W-CDMA state, see [“Storing a Custom W-CDMA State to Memory”](#) on page 2-20.

Inserting a PCCPCH Channel

After a normal instrument preset, the W-CDMA default downlink setup consists of one DPCH channel. In this example, a PCCPCH channel is inserted below the DPCH channel.

1. Press **Preset**.
2. Press **Mode > Arb Waveform Generator** (if it appears).
3. Press **CDMA Formats**.
4. Press **W-CDMA (3GPP 3.5 200103)** to display the W-CDMA menu.

- Press **W-CDMA Define > Edit Channel Setup** to display the channel table editor, as shown in the following figure.

| | | | | | | | | |
|-------------------------|-------|----------------------|-------------|---------------------|---------------|--------------------------------|------|---------------------------|
| FREQUENCY | | 4.000 000 000 00 GHz | | AMPLITUDE | | -135.00 dBm | | Edit Item |
| L | | | | RF OFF | | MOD ON | | Insert Row |
| Chip Rate: 3.840000Mcps | | Link: Down | | Total Power: 0.00dB | | Channel Code Domain: 0032-0035 | | Delete Row |
| | Type | Rate ksp/s | Spread Code | Power dB | Timing Offset | TFCI | TPC | Scramble Code |
| 1 | DPCH | 30.0 | 8 | 0.00 | 0 | 0 | 5555 | 0 |
| 2 | ----- | ----- | --- | ----- | --- | --- | --- | --- |
| | | | | | | | | Adjust Code Domain Power |
| | | | | | | | | Display Code Domain Power |
| | | | | | | | | Goto Row |
| | | | | | | | | More (1 of 2) |

- Press **Insert Row > PCCPCH**. A PCCPCH channel is now inserted in the channel table editor, as shown in the following figure.

| | | | | | | | | |
|-------------------------|--------|----------------------|-------------|---------------------|---------------|--------------------------------|------|---------------|
| FREQUENCY | | 4.000 000 000 00 GHz | | AMPLITUDE | | -135.00 dBm | | PCCPCH |
| T | | | | RF OFF | | MOD ON | | SCCPCH |
| Chip Rate: 3.840000Mcps | | Link: Down | | Total Power: 3.01dB | | Channel Code Domain: 0000-0000 | | PSCH |
| | Type | Rate ksp/s | Spread Code | Power dB | Timing Offset | TFCI | TPC | Scramble Code |
| 1 | DPCH | 30.0 | 8 | 0.00 | 0 | 0 | 5555 | 0 |
| 2 | PCCPCH | 15.0 | 8 | 0.00 | N/A | N/A | N/A | 0 |
| 3 | ----- | ----- | --- | ----- | --- | --- | --- | --- |
| | | | | | | | | SSCH |
| | | | | | | | | CPICH |
| | | | | | | | | DPCH |
| | | | | | | | | More (1 of 2) |

- Press **Return** until the status screen appears. The text area displays DL WCDMA Setup: 1 DPCH (Modified) as the current configuration.

To store a custom W-CDMA state, see [“Storing a Custom W-CDMA State to Memory”](#) on page 2-20.

Editing Downlink Channel Values in the Table Editor

You can use the channel setup table editor to modify downlink configuration values in the following columns:

- Rate ksps - symbol rate in kilosymbols-per-second
- Spread Code
- Power dB - channel power in decibels
- tDPCH Offset
- TFCI - transport format combination indicator
- TPC - transmit power control in hexadecimal
- Scramble Code
- TFCI Power - power offset in decibels
- TPC Power - power offset in decibels
- Pilot Power - power offset in decibels
- Pilot Bits - number of pilot bits
- Data - specific or random data
- Scramble Type
- Scramble Offset

Highlight the value you wish to change using the front panel arrows or knob, then enter the new value using the numeric keypad or select from the softkeys that appear when you press **Edit Item**.

In the following example, you will edit the TPC, TFCI Power, TPC Power, Pilot Power, Pilot Bits, Data, Scramble Type, and Scramble Offset fields of the default predefined channel selection for downlink.

1. Press **Preset > Mode > Arb Waveform Generator** (if it appears) > **CDMA Formats**.
2. Press **W-CDMA (3GPP 3.5 200103)** to display the W-CDMA menu. The default predefined channel selection for downlink is 1 DPCH.

- Press **W-CDMA Define > Edit Channel Setup** to display the channel table editor, as shown in the following figure. Use the front panel knob or arrow keys to move the cursor to table row 1.

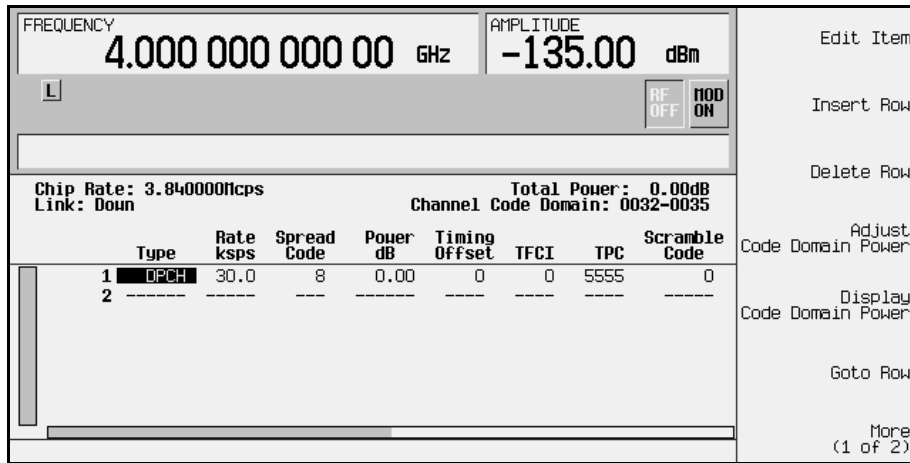

- Use the right arrow key to highlight the TPC value. 5555 should be highlighted. Press **Edit Item** and enter **00FF** using the letter softkeys and numeric keypad.

NOTE TPC values are entered as hexadecimal digits (0-9, A-F). For information on what these values represent, refer to [“Understanding TPC Values”](#) on page 4-6.

- Press **Enter**. The TPC value has now been modified and the cursor has moved to the next row in the TPC column, as shown in the following figure.

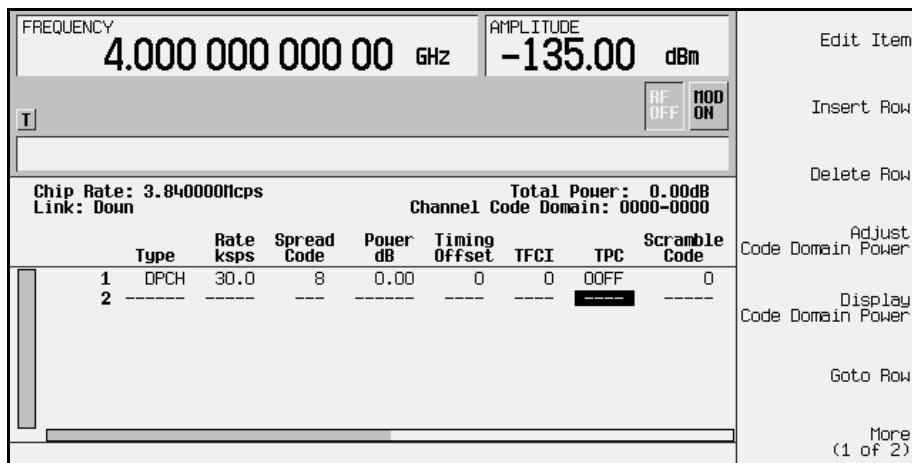

- Use the right arrow key to move the cursor to the TFCI Power dB field, which is currently hidden from view. (The horizontal scroll bar at the bottom of the screen indicates that there are columns to the right of the Scramble Code column.)

7. Use the arrow keys to edit the following fields:

- Highlight 0.00 dB in the TFCI Power field and press **Edit Item > 2 > dB**. The TFCI power has now been offset by 2 dB.
- Highlight 0.00 dB in the TPC Power field and press **Edit Item > 3 > dB**. The TPC power has now been offset by 3 dB.
- Highlight 0.00 dB in the Pilot Power field and press **Edit Item > 1 > dB**. The pilot power has now been offset by 1 dB.

NOTE For conceptual information on TFCI, TPC, and pilot power offsets, refer to [“Understanding TFCI, TPC, and Pilot Power Offsets”](#) on page 4-7.

- Highlight 4 in the Pilot Bits field and press **Edit Item > 8**. The number of pilot bits has now been changed to 8.
- Highlight Random in the Data field and press **Edit Item > PN9**. The channel data has now been changed to a PN9 bit pattern.
- Highlight STD in the Scramble Type field and press **Edit Item > Right Alternate**. Selecting right alternate adds 16384 to the actual scramble code.
- Highlight 0 in the Scramble Offset field and press **Edit Item > 1 > Enter**. The scramble code has now been changed from a primary code to a secondary code by entering a non-zero value. The scramble offset field has a range from 1 to 15.

NOTE For conceptual information on Scramble Type and Scramble Offset, refer to [“Calculating Downlink Scramble Codes”](#) on page 4-16.

The cursor has moved to the next row in the Pilot Power column, as shown in the following figure.

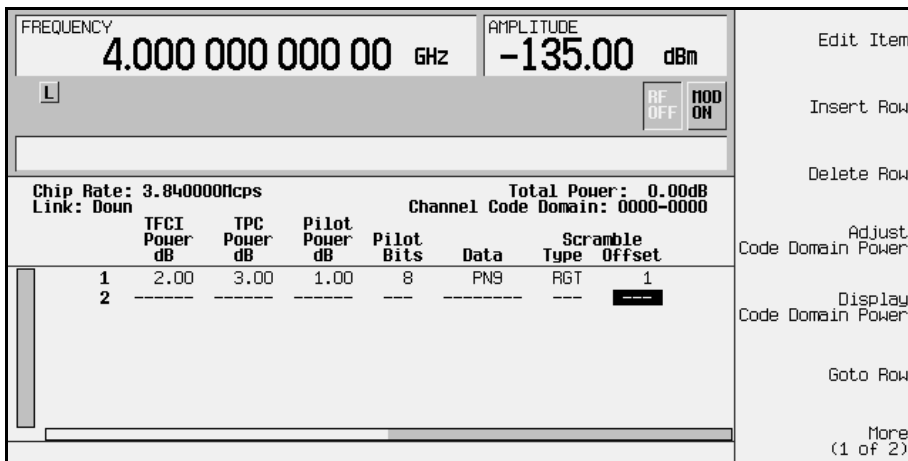

8. Press **Return** until the status screen appears. The text area displays DL WCDMA Setup: 1 DPCH (Modified) as the current configuration.

To store a custom W-CDMA state, see [“Storing a Custom W-CDMA State to Memory”](#) on page 2-20.

Modifying Uplink Channel Configurations

You can modify uplink channel configurations using the channel setup table editor. The following examples show you how to modify predefined channel setups for uplink waveform configurations. Refer to [“Table Editor Basics”](#) on page 2-2 for additional information about table editors.

CAUTION

Unless previously saved to the signal generator’s memory catalog, modifications made to predefined channel configurations are lost when changes are made to link direction.

To store a custom W-CDMA state, see [“Storing a Custom W-CDMA State to Memory”](#) on page 2-20.

Inserting Additional Channels

The default uplink channel setup after a normal instrument preset is one dedicated physical control channel (DPCCH). The DPCCH channel always occupies row 1 in the table editor and is modulated as a Q component. Any additional channels inserted into the table editor are DPDCH. The first DPDCH channel occupies row 2 and is modulated with an I component. The remaining channels (row 3 and greater) can be modulated with either I or Q, but no two consecutive channels except 2 and 3 are allowed to have the same component. The maximum number of uplink channels is 7.

The following example explains how to insert DPDCH channels into the uplink configuration.

Inserting Additional DPDCH Channels

In this example, six additional DPDCH channels are inserted into the default predefined uplink configuration.

1. Press **Preset > Mode > Arb Waveform Generator** (if it appears) > **CDMA Formats**.
2. Press **W-CDMA (3GPP 3.5 200103)** to display the W-CDMA menu.
3. Press **Link Down Up**. The display reflects the change to uplink mode. The text area displays **UL WCDMA Setup: DPCCH** as the current configuration, as shown in the following figure.



4. Press **W-CDMA Define > Edit Channel Setup** to display the channel table editor as shown in the following figure.

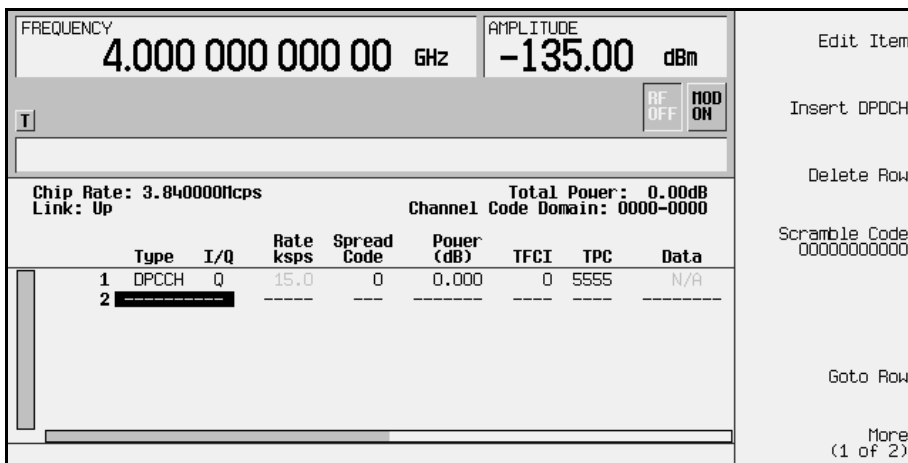

5. Press **Insert DPDCH > Channels**. To enter the value, rotate the front panel knob, use the up and down arrow keys until the number 6 is displayed, or enter 6 using the numeric keypad. Terminate the entry with the **Enter** softkey.

- Press **Done**. The channel table editor now contains the 6 additional channels, as shown in the following figure.

| | | | | | | | | | |
|--------------------------|-------|----------------------|------------|---------------------|------------|--------------------------------|------|------------|-----------------------------|
| FREQUENCY | | 4.000 000 000 00 GHz | | AMPLITUDE | | -135.00 dBm | | Edit Item | |
| RF OFF | | MOD ON | | Insert DPDCH | | | | | |
| Chip Rate: 3.840000 Mcps | | Link: Up | | Total Power: 8.45dB | | Channel Code Domain: 0000-0000 | | Delete Row | |
| | Type | I/Q | Rate ksp/s | Spread Code | Power (dB) | TFCI | TPC | Data | Scramble Code 0000000000 |
| 1 | DPDCH | Q | 15.0 | 0 | 0.000 | 0 | 5555 | N/A | Goto Row |
| 2 | DPDCH | I | 60.0 | 1 | 0.000 | N/A | N/A | RANDOM | |
| 3 | DPDCH | Q | 60.0 | 2 | 0.000 | N/A | N/A | RANDOM | |
| 4 | DPDCH | I | 60.0 | 3 | 0.000 | N/A | N/A | RANDOM | |
| 5 | DPDCH | Q | 60.0 | 4 | 0.000 | N/A | N/A | RANDOM | |
| 6 | DPDCH | I | 60.0 | 5 | 0.000 | N/A | N/A | RANDOM | |
| 7 | DPDCH | Q | 60.0 | 6 | 0.000 | N/A | N/A | RANDOM | |
| END | | | | | | | | | |
| More (1 of 2) | | | | | | | | | |

- Press **Second DPDCH I Q** until **I** highlights, as shown in the following figure. The I/Q setting for the second DPDCH channel (row 3) has changed from Q to I. Additionally, all subsequent channels have also switched I/Q settings.

| | | | | | | | | | |
|--------------------------|-------|----------------------|------------|---------------------|------------|--------------------------------|------|-----------------------------|----------------------------------|
| FREQUENCY | | 4.000 000 000 00 GHz | | AMPLITUDE | | -135.00 dBm | | Reset Table | |
| RF OFF | | MOD ON | | Chip Rate | | 3.840000 Mcps | | | |
| Chip Rate: 3.840000 Mcps | | Link: Up | | Total Power: 8.45dB | | Channel Code Domain: 0000-0000 | | TFCI Field Off On | |
| | Type | I/Q | Rate ksp/s | Spread Code | Power (dB) | TFCI | TPC | Data | Second DPDCH I Q |
| 1 | DPDCH | Q | 15.0 | 0 | 0.000 | 0 | 5555 | N/A | Gain Unit dB Lin Index |
| 2 | DPDCH | I | 60.0 | 1 | 0.000 | N/A | N/A | RANDOM | |
| 3 | DPDCH | I | 60.0 | 2 | 0.000 | N/A | N/A | RANDOM | |
| 4 | DPDCH | Q | 60.0 | 3 | 0.000 | N/A | N/A | RANDOM | |
| 5 | DPDCH | I | 60.0 | 4 | 0.000 | N/A | N/A | RANDOM | |
| 6 | DPDCH | Q | 60.0 | 5 | 0.000 | N/A | N/A | RANDOM | |
| 7 | DPDCH | I | 60.0 | 6 | 0.000 | N/A | N/A | RANDOM | |
| END | | | | | | | | | |
| More (2 of 2) | | | | | | | | | |

- Press **Return** until the status screen appears. The text area displays UL WCDMA Setup: DPDCH (Modified) as the current configuration.

To store a custom W-CDMA state, see “Storing a Custom W-CDMA State to Memory” on page 2-20.

Editing Uplink Channel Values in the Table Editor

You can use the channel setup table editor to modify uplink configuration values in the following columns:

- Rate ksps - symbol rate in kilosymbols-per-second
- Spread Code
- Power dB - channel power in decibels
- TFCI - transport format combination indicator
- TPC - transmit power control in hexadecimal
- Data - specific or random data
- FBI Bits Count- number of bits in channel
- FBI Bits Value - value for the FBI bits

Highlight the value you wish to change using the front panel arrows or knob, then enter the new value using the numeric keypad.

In the following example, you will edit the TPC, FBI Bits Count, and FBI Bits Value fields of the default predefined channel selection for uplink, which is one dedicated physical control channel (1 DPCCH).

1. Press **Preset > Mode > Arb Waveform Generator** (if it appears) > **CDMA Formats**.
2. Press **W-CDMA (3GPP 3.5 200103)** to display the W-CDMA menu.
3. Press **Link Down Up**. The display reflects the change to uplink mode. The text area displays **UL WCDMA Setup: DPCCH** as the current configuration, as shown in the following figure.



- Press **W-CDMA Define > Edit Channel Setup** to display the channel table editor, as shown in the following figure.

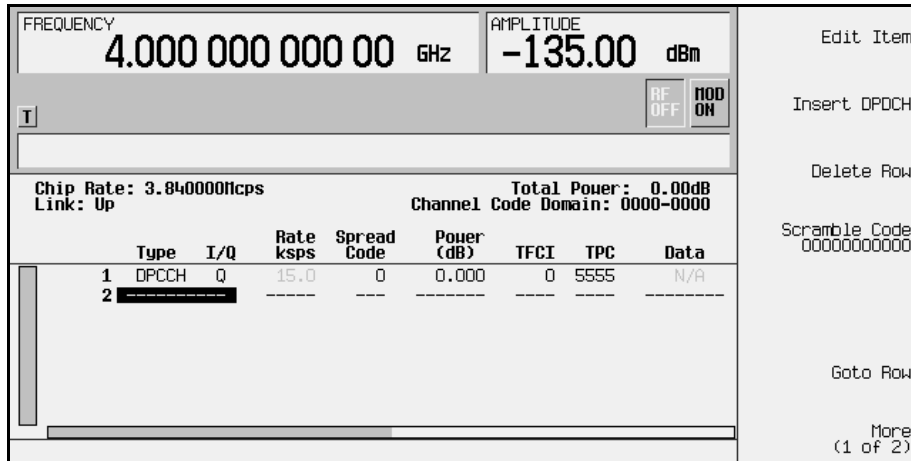

- Use the right arrow key to scroll to the TPC value 5555, it should be highlighted.

NOTE TPC values are entered as hexadecimal digits (0-9, A-F). For information on what these values represent, refer to [“Understanding TPC Values”](#) on page 4-6.

- Press **Edit Item** and enter **00FF** using the letter softkeys and numeric keypad. Press **Enter**. The TPC value has now been modified and the cursor has moved to the next row in the TPC column, as shown in the following figure.

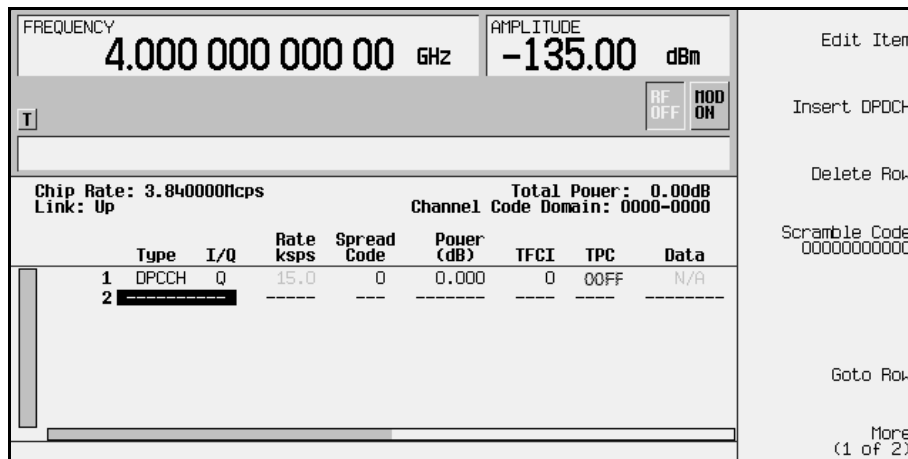

7. Use the right arrow key to move the cursor to the FBI Bits Count and FBI Bits Value fields which are currently hidden from view. Use the arrow keys to edit these fields:
 - Highlight 0 in the FBI Bits Count field and press **Edit Item > 1 > Enter**. The FBI Bits Count field has been changed to 1.
 - Highlight 0 in the FBI Bits Value field and press **Edit Item > 1 > Enter**. The FBI Bits Value field has changed to 1.

The cursor has moved to the next row in the FBI Bits Value column, as shown in the following figure.

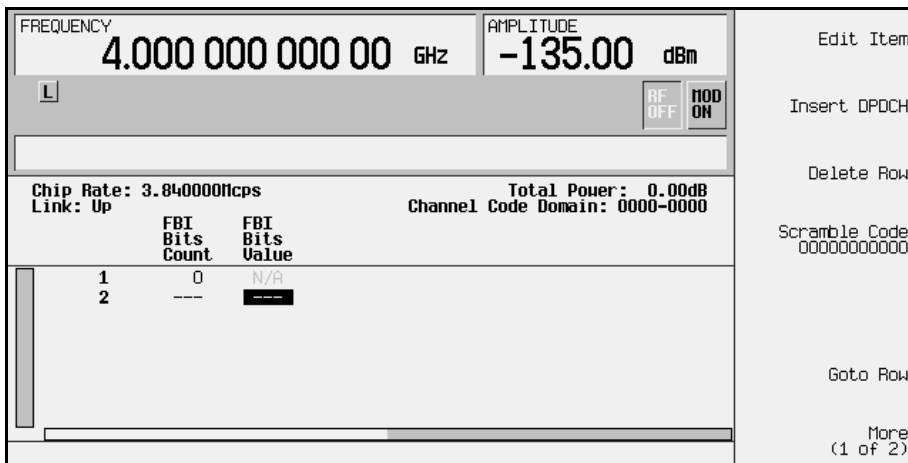

8. Press **Return** until the status screen appears. The text area displays UL WCDMA Setup: DPCH (Modified) as the current configuration.

To store a custom W-CDMA state, see [“Storing a Custom W-CDMA State to Memory”](#) on page 2-20.

Storing a Custom W-CDMA State to Memory

In this procedure, you will store the custom W-CDMA state created in the previous procedure. If you have not performed the previous procedure, turn to “[Editing Uplink Channel Values in the Table Editor](#)” on page 2-17 and complete this procedure before continuing.

Use the following procedure to store the custom W-CDMA state to the signal generator’s memory catalog.

- To store the custom W-CDMA state, press **Store Custom W-CDMA State**. This opens a menu that accesses the signal generator’s up W-CDMA (UWCDMA) memory catalog, as shown in the following figure.

NOTE The downlink W-CDMA memory catalog is named DWCDMA.

| | | | | |
|--|--|------------------------------------|--|------------------|
| FREQUENCY 4.000 000 000 00 GHz | | AMPLITUDE -135.00 dBm | | Store To File |
| T | | RF OFF MOD ON | | |
| Catalog of UWCDMA Files | | 198464 bytes used 77444 bytes free | | Delete File |
| | | File Name Type Size | | Goto Row▶ |
| | | | | Page Up |
| | | | | Page Down |

- To name the custom W-CDMA state, press **Store to File**. This opens a menu that allows you to name the custom W-CDMA state, as shown in the following figure.

| | | | | |
|--|--|------------------------------------|--|----------------|
| FREQUENCY 4.000 000 000 00 GHz | | AMPLITUDE -135.00 dBm | | Enter |
| T | | RF OFF MOD ON | | |
| Store to: | | | | Editing Keys▶ |
| Catalog of UWCDMA Files | | 198464 bytes used 77444 bytes free | | A B C D E F G |
| | | File Name Type Size | | H I J K L M N |
| | | | | O P Q R S T U |
| | | | | V W X Y Z _ \$ |
| | | | | & # + - [] █ |

- If there is already a file highlighted in the catalog, press **Editing Keys > Clear Text**, then use the alphabetic menu and the numeric keypad to enter the file name **CUSTOMUP1**. Press **Enter**. Your custom W-CDMA state **CUSTOMUP1** is now saved to the uplink W-CDMA memory catalog, as shown.

| | | | | |
|--|-----------|--|------|--|
| FREQUENCY 4.000 000 000 00 GHz | | AMPLITUDE -135.00 dBm | | Store To File |
| <input type="checkbox"/> I | | RF OFF <input type="checkbox"/> MOD ON | | |
| Catalog of DWCDMA Files 199744 bytes used 76164 bytes free | | | | Delete File |
| | File Name | Type | Size | |
| 1 | CUSTOMUP1 | DWCD | 152 | Goto Row → Page Up Page Down |

Creating, Storing, & Recalling a Custom Multicarrier W-CDMA Waveform

The signal generator provides a quick and easy way to create custom multicarrier W-CDMA waveforms: rather than building an entire 4-carrier setup from scratch, you can start with a 4-carrier W-CDMA template and modify the template's default values as desired.

Use the following procedure to create, store, and recall a custom, 4-carrier W-CDMA waveform.

Opening the Multicarrier W-CDMA Setup Table Editor

1. Press **Preset**.
2. Press **Mode** > **Arb Waveform Generator** (if it appears).
3. Press **CDMA Formats** > **W-CDMA (3GPP 3.5 200103)** > **Multicarrier Off On**.
4. Press **W-CDMA Select** > **4 Carriers** to select the template and return to the previous menu.
5. Press **Multicarrier Define** to open the Multicarrier W-CDMA Setup table editor. The 4-carrier W-CDMA template is automatically placed in the table editor, as shown in the following figure.

Active Entry Area

Multicarrier W-CDMA Setup softkeys

| Carrier | Freq Offset | Power | |
|---------|--------------|---------------|---------|
| 1 | PCCPCH + SCH | -7.500000 MHz | 0.00 dB |
| 2 | PCCPCH + SCH | -2.500000 MHz | 0.00 dB |
| 3 | PCCPCH + SCH | 2.500000 MHz | 0.00 dB |
| 4 | PCCPCH + SCH | 7.500000 MHz | 0.00 dB |
| END | | | |

Carrier Type

Frequency Offset Value

Power Value

Modifying a Multicarrier W-CDMA 4-Carrier Template

Use the following steps to modify the standard 4-carrier W-CDMA template that was loaded in the previous procedure.

Edit the second carrier.

1. Highlight the second channel carrier (in table row 2), then press **Edit Item**.
2. Press **3 DPCH**. This changes the carrier type.
3. Highlight the second carrier's frequency offset value and press **Edit Item**.
4. Change the offset value to **-625** and press **kHz**.
5. Highlight the second carrier's power value and press **Edit Item**.
6. Change the power value to **-10** and press **dB**.

The following figure shows the edited template:

| | | | | | | | | |
|-------------------------------|--------------|----------------------|-----------|-----------|--|-------------|--|------------|
| FREQUENCY | | 4.000 000 000 00 GHz | | AMPLITUDE | | -135.00 dBm | | Edit Item |
| I | | | | RF OFF | | HOD ON | | Insert Row |
| Multicarrier WCDMA 3GPP Setup | | | | | | | | |
| | Carrier | Freq Offset | Power | | | | | |
| 1 | PCCPCH + SCH | -7.500000 MHz | 0.00 dB | | | | | |
| 2 | 3 DPCH | -625.000 kHz | -10.00 dB | | | | | |
| 3 | PCCPCH + SCH | 2.500000 MHz | 0.00 dB | | | | | |
| 4 | PCCPCH + SCH | 7.500000 MHz | 0.00 dB | | | | | |
| END | ----- | ----- | ----- | | | | | |
| Store Custom Multicarrier | | | | | | | | |
| Apply Multicarrier | | | | | | | | |

Activating a Custom Multicarrier W-CDMA Setup

Using the custom 4-carrier W-CDMA setup from the previous procedure, perform the following steps to activate the custom multicarrier W-CDMA signal.

1. Press **Return**, and note that the multicarrier setup is now displayed as Multicarrier Setup: 4 Carriers (Modified).

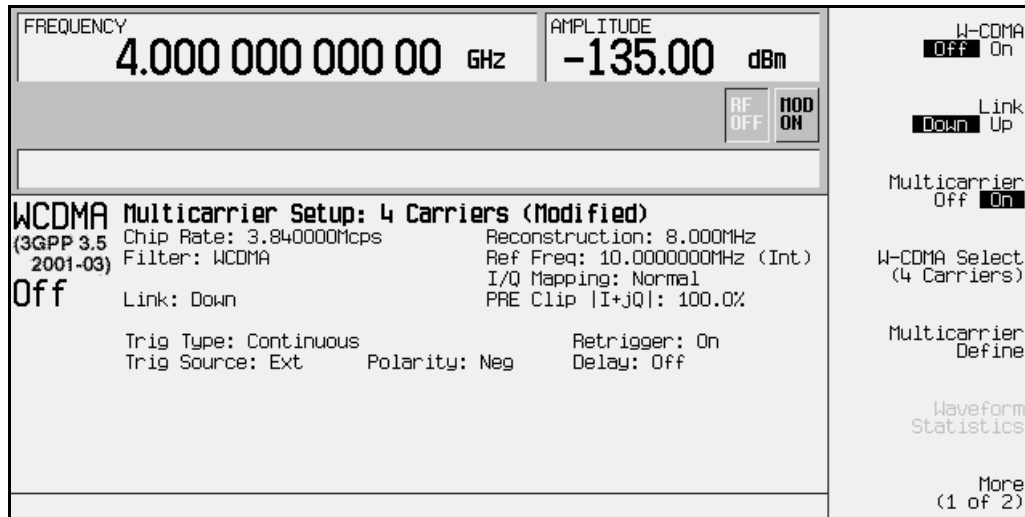

2. Press **W-CDMA Off On**. After waveform generation, the new multicarrier W-CDMA waveform is stored in volatile memory.
3. Press **RF On/Off**. The **RF ON** annunciator replaces the **RF OFF** annunciator on the signal generator's display, as shown, and the modulated signal is present at the RF output.

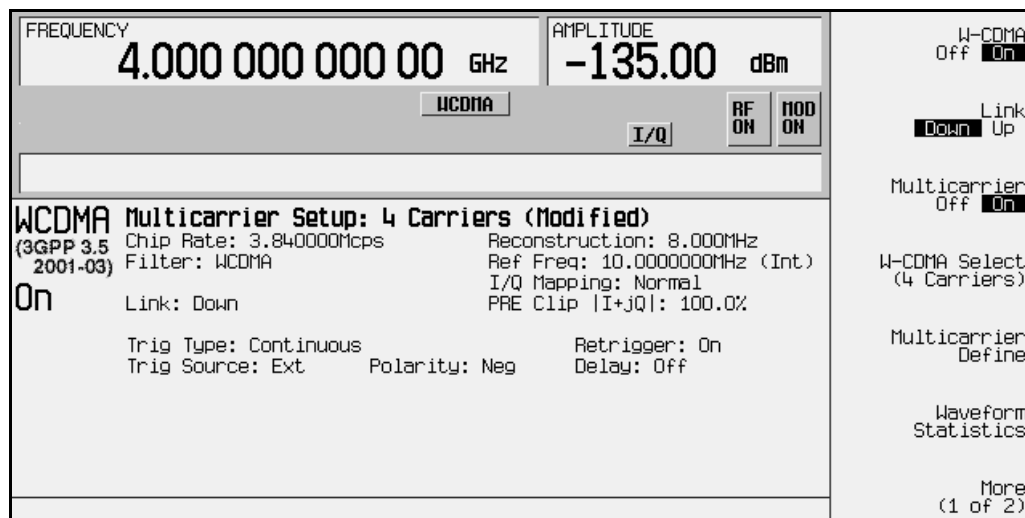

Storing a Custom Multicarrier W-CDMA Waveform

Use the following procedure to store a custom multicarrier W-CDMA waveform to the signal generator's memory. This example uses the custom 4-carrier W-CDMA waveform created in the previous procedure. If you have not created this custom multicarrier W-CDMA waveform, refer to [“Creating, Storing, & Recalling a Custom Multicarrier W-CDMA Waveform”](#) on page 2-22.

1. Press **Mode** > **Arb Waveform Generator** (if it appears) > **CDMA Formats** > **W-CDMA (3GPP 3.4 12-00)** > **Multicarrier Off On** > **Multicarrier Define**.
2. Press **Store Custom Multicarrier** to display the signal generator's catalog of multicarrier down W-CDMA (DCDMA) files.
3. Press **Store To File** to open a file naming softkey menu of letters and symbols that you can use to name the file.
4. As described in [“Storing a Custom W-CDMA State to Memory”](#) on page 2-20, name and store this file as 4CARRIER.

Recalling a Custom Multicarrier W-CDMA Waveform

Use the following procedure to recall the custom multicarrier W-CDMA state from the MFWCDMA memory catalog. This example recalls the custom 4-carrier W-CDMA waveform stored in the previous procedure.

1. Press **Preset**.
2. Press **Mode** > **Arb Waveform Generator** (if it appears) > **CDMA Formats** > **W-CDMA (3GPP 3.4 12-00)** > **Multicarrier Off On**.
3. Press **W-CDMA Select** > **Custom W-CDMA Multicarrier** to open the MFWCDMA memory catalog.
4. Highlight the file 4CARRIER, then press **Select File**. The custom multicarrier W-CDMA waveform 4CARRIER is selected.

You can now use the waveform. For details, refer to [“Activating a Custom Multicarrier W-CDMA Setup”](#) on page 2-24.

Identifying and Resolving Code Domain Conflicts

The code domain space of each channel is defined by the symbol rate and spread code. Code domain conflicts can arise when two channels of different rates map to the same code domain space. If code domain conflicts are present when the waveform is turned on, the conflicting channels are still generated.

NOTE Although the examples in this section use the downlink channel configuration, the information also applies to uplink.

Identifying Conflicts

The following figure shows two code domain conflicts. In this example, row 2 occupies the channel code domain of 0024-0031. Row 5 conflicts with row 2 by occupying the channel code domain of 0024-0027. Row 6 also conflicts with row 2 by occupying the channel code domain of 0028-0031. The conflicting channels (rows 5 and 6) are flagged (highlighted) and each flag includes the row number of the channel it conflicts with, as shown.

| FREQUENCY | | AMPLITUDE | | | | | | | | | Edit Item |
|-------------------------|------|-------------|-------------|--------------------------------|---------------|------|------|---------------|----------------------------|-------------|-------------|
| 4.000 000 000 00 GHz | | -135.00 dBm | | | | | | | | | |
| I | | RF OFF | | MOD ON | | | | | | | Insert Row▶ |
| | | | | | | | | | | Delete Row▶ | |
| Chip Rate: 3.840000Mcps | | | | Total Power: 13.22dB | | | | | | | |
| Link: Down | | | | Channel Code Domain: 0056-0059 | | | | | | | |
| Domain Conflict | Type | Rate ksp/s | Spread Code | Power dB | Timing Offset | TFCI | TPC | Scramble Code | | | |
| 1 | DPCH | 30.0 | 2 | 0.00 | 0 | 0 | 00FF | 0 | Adjust Code Domain Power▶ | | |
| 2 | DPCH | 60.0 | 3 | 0.00 | 0 | 0 | 5555 | 0 | Display Code Domain Power▶ | | |
| 3 | DPCH | 30.0 | 4 | 0.00 | 18 | 0 | 5555 | 0 | | | |
| 4 | DPCH | 30.0 | 5 | 0.00 | 2 | 0 | 5555 | 0 | | | |
| 2/5 | DPCH | 30.0 | 6 | 0.00 | 16 | 0 | 5555 | 0 | | | |
| 2/6 | DPCH | 30.0 | 7 | 0.00 | 4 | 0 | 5555 | 0 | Goto Row▶ | | |
| 7 | DPCH | 30.0 | 8 | 0.00 | 14 | 0 | 5555 | 0 | | | |
| 8 | DPCH | 30.0 | 14 | 0.00 | 6 | 0 | 5555 | 0 | More (1 of 2) | | |

Resolving Conflicts

To resolve conflicts, you can change the value of the spread code. To make changes, use the table editor functions to highlight the value you want to change, then enter the new value using the front panel keys. In the following figure, the spread code for the channel in row 2 has been changed to 9 to resolve the conflicts in rows 5 and 6.

| | | | | | | | | |
|---------------------------|------|----------------------|-------------|----------------------|---------------|--------------------------------|------|---------------|
| FREQUENCY | | 4.000 000 000 00 GHz | | AMPLITUDE | | -135.00 dBm | | Edit Item |
| I | | | | RF OFF | | MOD ON | | Insert Row |
| Chip Rate: 3.840000Mcps | | Link: Down | | Total Power: 12.79dB | | Channel Code Domain: 0056-0059 | | Delete Row |
| | Type | Rate ksp/s | Spread Code | Power dB | Timing Offset | TFCI | TPC | Scramble Code |
| 1 | DPCH | 30.0 | 2 | 0.00 | 0 | 0 | 00FF | 0 |
| 2 | DPCH | 60.0 | 9 | 0.00 | 0 | 0 | 5555 | 0 |
| 3 | DPCH | 30.0 | 4 | 0.00 | 18 | 0 | 5555 | 0 |
| 4 | DPCH | 30.0 | 5 | 0.00 | 2 | 0 | 5555 | 0 |
| 5 | DPCH | 30.0 | 6 | 0.00 | 16 | 0 | 5555 | 0 |
| 6 | DPCH | 30.0 | 7 | 0.00 | 4 | 0 | 5555 | 0 |
| 7 | DPCH | 30.0 | 8 | 0.00 | 14 | 0 | 5555 | 0 |
| 8 | DPCH | 30.0 | 14 | 0.00 | 6 | 0 | 5555 | 0 |
| Adjust Code Domain Power | | | | | | | | |
| Display Code Domain Power | | | | | | | | |
| Goto Row | | | | | | | | |
| More (1 of 2) | | | | | | | | |

Outputting a W-CDMA Waveform

This section explains how to set the carrier frequency and power, generate a W-CDMA waveform, enable the modulation and the RF output, and set the waveform's clipping parameters.

Setting the Carrier Frequency and Power

Use the following procedure to set the carrier signal's power and frequency.

1. Press **Preset**.
2. Press **Mode > Arb Waveform Generator** (if it appears).
3. Press **CDMA Formats**.
4. Press **W-CDMA (3GPP 3.5 200103)** to display the W-CDMA menu.
5. For this example, set the RF output frequency to 2.17 GHz by pressing the front panel **Frequency** key. Enter 2.17 GHz by rotating the front panel knob, using the up and down arrow keys, or entering the value using the numeric keypad. (If using the numeric keypad to enter a new value, terminate the entry with the **GHz** softkey.)
6. Set the output power to -10 dBm by pressing the front panel **Amplitude** key. Enter -10 by rotating the front panel knob, using the up and down arrow keys, or entering the value using the numeric keypad. (If using the numeric keypad to enter a new value, terminate the entry with the **dBm** softkey.)

The carrier frequency and power are now set. The following figure shows the display with the current configuration.

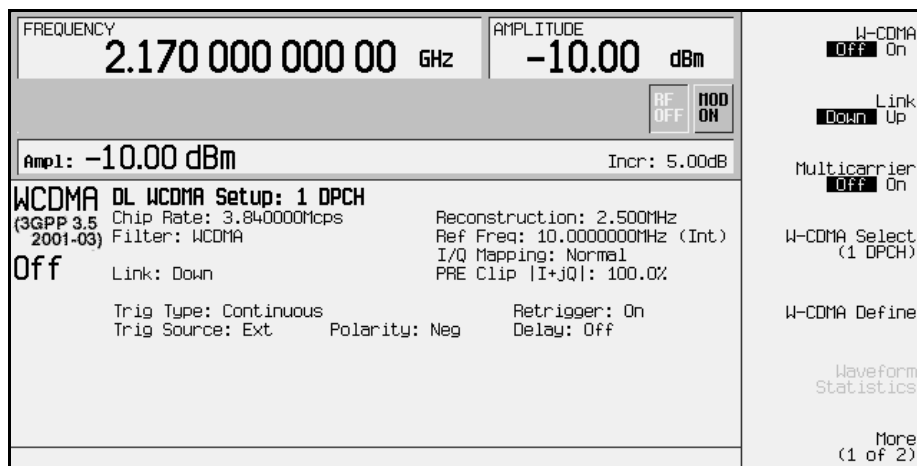

Generating the W-CDMA Waveform and Enabling the RF Output

Use the following procedure to generate a W-CDMA waveform and activate the RF output.

1. Press **W-CDMA Off On** to generate the W-CDMA waveform. (The signal generator displays a message while the waveform is being generated.) The **WCDMA** and **I/Q** annunciators turn on.
2. Toggle the front panel **RF On/Off** key until the display annunciator reads **RF ON**.
3. Modulation is turned on as a default condition. (The display annunciator shows **MOD ON**.) If modulation is off, toggle the front panel **Mod On/Off** key.

The W-CDMA signal is now present at the front panel **RF OUTPUT** connector. The following figure shows the display with the current configuration.

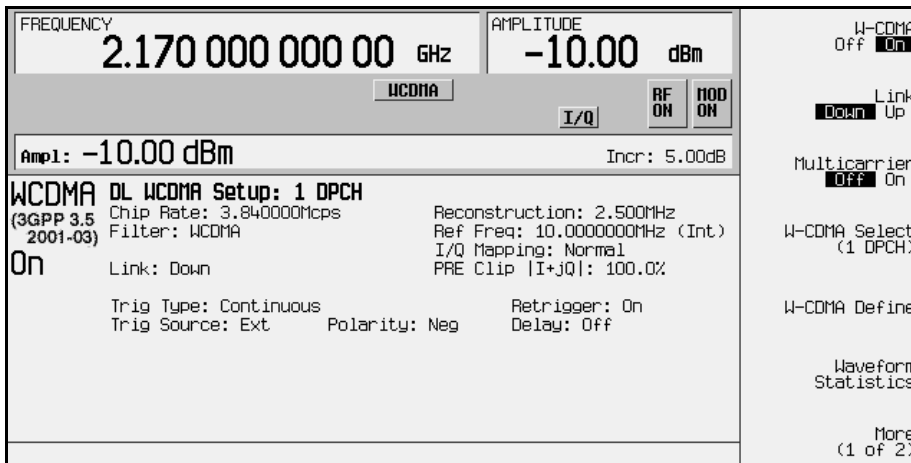

Clipping the W-CDMA Waveform

Use the following procedure to configure and apply clipping to the W-CDMA waveform.

1. In the status area of the display, the current clipping setup is **PRE Clip |I+jQ|: 100.0%**. A clipping level of 100 percent is equal to no clipping.
2. Press **W-CDMA Define > More (1 of 2) > Clipping** to access the clipping setup menu.
3. The **Clipping Type |I+jQ| ||,|Q|** softkey default is **|I+jQ|** (*circular clipping*). This selection clips the combined I and Q waveform. Alternatively, **||,|Q|** (*rectangular clipping*) clips the I and Q waveforms separately. Use the default selection for this example.
4. Press **Clip |I+jQ| To** and enter 80 percent.
5. The **Clip At PRE POST FIR Filter** softkey default is **PRE**. With **PRE** selected, the waveform is clipped prior to FIR filtering. Alternatively, when you select **POST**, the waveform is clipped after FIR filtering. Use the default selection for this example.

- Press **Apply to Waveform**. The signal generator rebuilds the waveform and the clipping settings are updated in the status area of the display, as shown. For more information on clipping, refer to “[Understanding Baseband Clipping](#)” on page 4-9.

| | | | | |
|--|--|---|---|----------------------------------|
| FREQUENCY 2.170 000 000 00 GHz | | AMPLITUDE -10.00 dBm | | ARB Reference Ext Int |
| WCDMA | | I/Q | | Reference Freq (N/A) |
| Clip I+jQ : 80.0 % | | RF ON | | I/Q Mapping Normal Invert |
| WCDMA DL WCDMA Setup: 1 DPCH (Modified) | | T100 ON | | Clipping (I+jQ) |
| (3GPP 3.5 2001-03) | Chip Rate: 3,840,000 Mcps Filter: WCDMA | Reconstruction: 2.500 MHz Ref Freq: 10.000,000 MHz (Int) | I/Q Mapping: Normal PRE Clip I+jQ : 80.0% | More (2 of 2) |
| On | Link: Down | Trig Type: Continuous Trig Source: Ext | Polarity: Neg Retrigger: On Delay: Off | |

Creating a User-Defined FIR Filter Using the FIR Table Editor

Using this procedure you will create and store an 8-symbol, windowed sinc function filter with an oversample ratio of 4.

Accessing the Table Editor

Use the following procedure to access the FIR filter table editor.

1. Press **Preset**.
2. Press **Mode > Arb Waveform Generator** (if it appears).
3. Press **CDMA Formats**.
4. Press **W-CDMA (3GPP 3.5 200103) > W-CDMA Define > Filter > Define User FIR**. The FIR table editor is displayed. The following figure shows the FIR table editor.

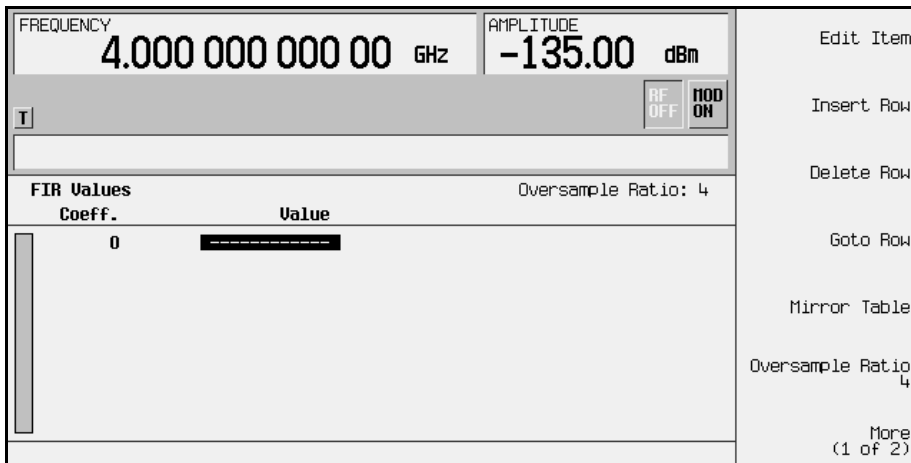

Entering the Coefficient Values

The FIR table editor creates a filter from values that you provide.

1. Use the cursor to highlight the `value` field for coefficient 0. Use the numeric keypad to type the first value (-0.000076) from the following table. As you press the numeric keys, the numbers are displayed in the active entry area.

| Coefficient | Value |
|-------------|-----------|
| 0 | -0.000076 |
| 1 | -0.001747 |
| 2 | -0.005144 |
| 3 | -0.004424 |
| 4 | 0.007745 |
| 5 | 0.029610 |
| 6 | 0.043940 |
| 7 | 0.025852 |

| Coefficient | Value |
|-------------|-----------|
| 8 | -0.035667 |
| 9 | -0.116753 |
| 10 | -0.157348 |
| 11 | -0.088484 |
| 12 | 0.123414 |
| 13 | 0.442748 |
| 14 | 0.767329 |
| 15 | 0.972149 |

Press **Enter**. The value for coefficient 0 is now displayed in the `value` field, and the cursor has moved to the second row in the `value` column. The following figure shows the FIR table editor at this point in the process.

2. Continue entering the coefficient values from the table in step 1 until all 16 values are complete.

Duplicating the First 16 Coefficients Using Mirror Table

Use the following procedure to duplicate the first 16 coefficients in the FIR filter table editor.

In a windowed sinc function filter, the second half of the coefficients are identical to the first half in reverse order. The signal generator provides a mirror table function that automatically duplicates the existing coefficient values in the reverse order.

Press **Mirror Table**. The last 16 coefficients (16 through 31) are automatically generated and the first of these coefficients (number 16) highlights. The following figure shows the display at this point in the process.

The screenshot shows the FIR Table Editor interface. At the top, the frequency is set to 4.000 000 000 00 GHz and the amplitude is -135.00 dBm. Below this, there are buttons for 'RF OFF' and 'MOD ON'. The main table is titled 'FIR Values (UNSTORED)' and shows coefficients 10 through 19. The 'Oversample Ratio' is set to 4. The coefficient values are: 10: -0.157348, 11: -0.088484, 12: 0.123414, 13: 0.442748, 14: 0.767329, 15: 0.972149, 16: 0.972149 (highlighted), 17: 0.767329, 18: 0.442748, 19: 0.123414. On the right side, there are control buttons: 'Edit Item', 'Insert Row', 'Delete Row', 'Goto Row', 'Mirror Table', 'Oversample Ratio 4', and 'More (1 of 2)'.

| Coeff. | Value |
|--------|-----------|
| 10 | -0.157348 |
| 11 | -0.088484 |
| 12 | 0.123414 |
| 13 | 0.442748 |
| 14 | 0.767329 |
| 15 | 0.972149 |
| 16 | 0.972149 |
| 17 | 0.767329 |
| 18 | 0.442748 |
| 19 | 0.123414 |

Setting the Oversample Ratio

The oversample ratio (OSR) is the number of filter coefficients per symbol. Acceptable values range from 1 through 32; the maximum combination of symbols and oversampling ratio allowed by the table editor is 1024. The instrument hardware, however, is actually limited to 32 symbols, an oversample ratio between 4 and 16, and 256 coefficients. So if you enter more than 32 symbols or 256 coefficients, the instrument is unable to use the filter. If the oversample ratio is different from the internal, optimally selected one, then the filter is automatically resampled to an optimal oversample ratio.

The current OSR value is shown underneath the **Oversample Ratio** softkey, as shown in the previous figure. For this example, set the OSR to 4 (if it isn't already). Press **Oversample Ratio** and use the numeric keypad to enter 4. Press the **Enter** softkey to terminate the entry.

Displaying a Graphical Representation of the Filter

Use the following procedure to display graphical representations of the active FIR filter.

The signal generator has the capability of graphically displaying the filter in both time and frequency dimensions.

1. Press **More (1 of 2) > Display FFT** to view the filter frequency response (calculated using a fast Fourier transform). The following graph is displayed.

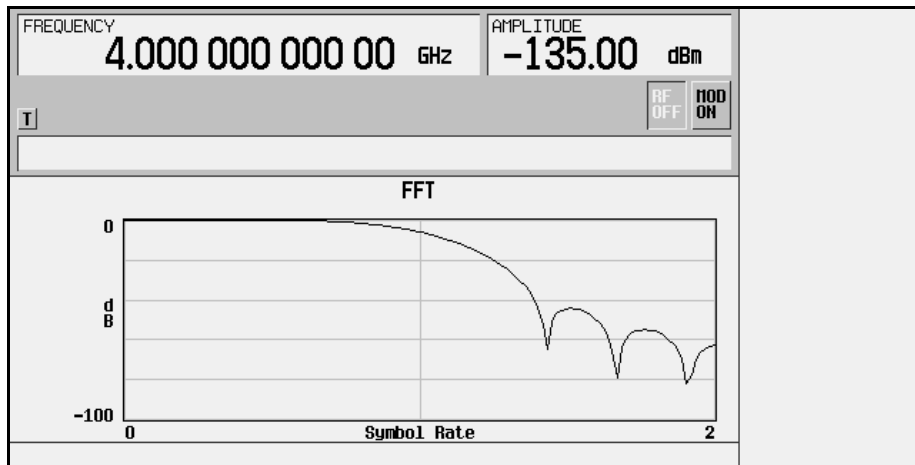

2. Press **Return** to return to the menu keys.
3. Press **Display Impulse Response** to display the filter impulse response in time. The following graph is displayed.

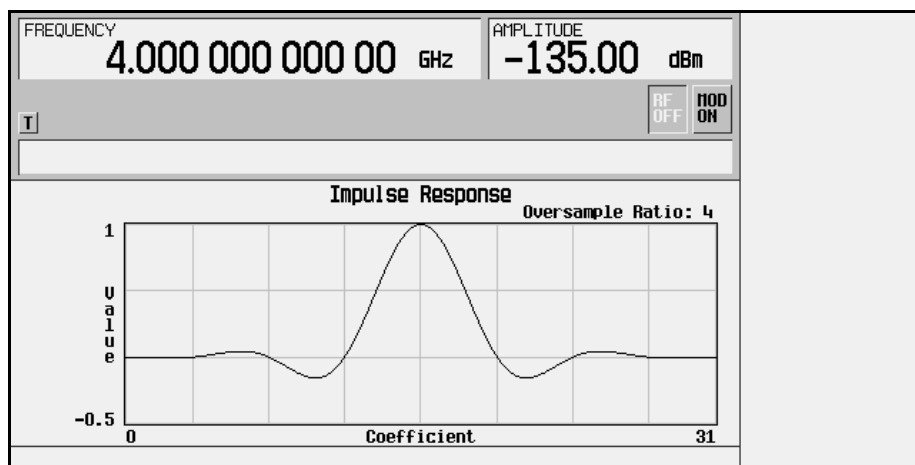

4. Press **Return** to return to the menu keys.

Storing the Filter to Memory

The filter is now complete and can be stored to non-volatile memory for future use. At any time you can check the information at the top of the FIR table editor to determine whether the current table has been stored. Your current table should display the following text: FIR Values (UNSTORED). If you attempt to exit the table editor mode without first storing to a file, the signal generator first prompts you to confirm that you want to exit without storing to a file. If you do *not* want to exit after all, press **Return**.

To store the file, perform the following steps.

1. Press **Load/Store > Store To File**. The catalog of FIR files appears along with the amount of memory available.
2. For this example, you will title the file NEWFIR1. The file name is created by pressing the softkey containing the desired character, then selecting the softkey with that character from the subsequent menu. For example, press the **HIJKLMN** softkey. Then press the bottom softkey, **N**. **N** is displayed in the active entry area following the **Store to:** text.
3. Continue entering the characters for the file name until NEWFIR1 is displayed in the active entry area. (Use the numeric keypad to enter the number 1.)
4. Press **Enter** when the file name is complete. The contents of the current FIR table editor are stored to a file in non-volatile memory. The following figure shows the display.

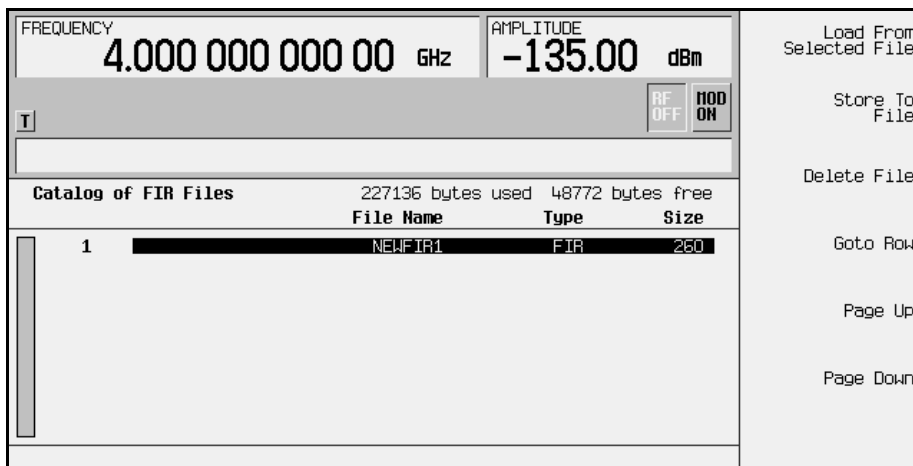

The NEWFIR1 file is the first file name listed. (If you have previously stored other FIR files, additional file names are listed below NEWFIR1.) The file type is FIR and the size of the file is 260 bytes. The amount of memory used is also displayed. The number of files that can be saved depends on the size of the files and the amount of memory used. Memory is also shared by instrument state files and list sweep files.

This filter can now be used to customize a modulation or it can be used as a basis for a new filter design. (Refer to the additional filter examples in this chapter.)

Modifying an FIR Filter Using the FIR Table Editor

FIR filters stored in the signal generator memory can easily be modified using the FIR table editor. You can load the FIR table editor with coefficient values from user-defined FIR files stored in the signal generator's memory, or from one of the default FIR filters. Then you can modify the values, and store the new files. In this example, you will load the FIR table editor with the values for a default Gaussian filter and then modify it.

Loading the Default Gaussian FIR File

Use the following procedure to load the default Gaussian FIR filter into the FIR filter table editor.

1. Press **Preset > Mode > Arb Waveform Generator** (if it appears).
2. Press **CDMA Formats > W-CDMA (3GPP 3.5 200103) > W-CDMA Define**.
3. Press **Filter > Define User FIR > More (1 of 2) > Load Default FIR > Gaussian**.
4. Set the filter BbT to 0.300 (if **Filter BbT** is not already set to this value) by pressing **Filter BbT** and rotate the front panel knob until 0.300 is displayed.
5. Set the number of filter symbols to 8 by pressing **Filter Symbols** and rotating the front panel knob until 8 is displayed.
6. Press **Generate**. The FIR table editor should now contain the coefficient values for the specified Gaussian filter.

NOTE

The actual oversample ratio during modulation is automatically selected by the instrument. A value between 4 and 16 is chosen dependent on the symbol rate, the number of bits per symbol of the modulation type, and the number of symbols.

- Press **Display Impulse Response** for a graphic representation of the filter impulse response as shown in the following figure.
- Press **Return** to return to the menu keys.

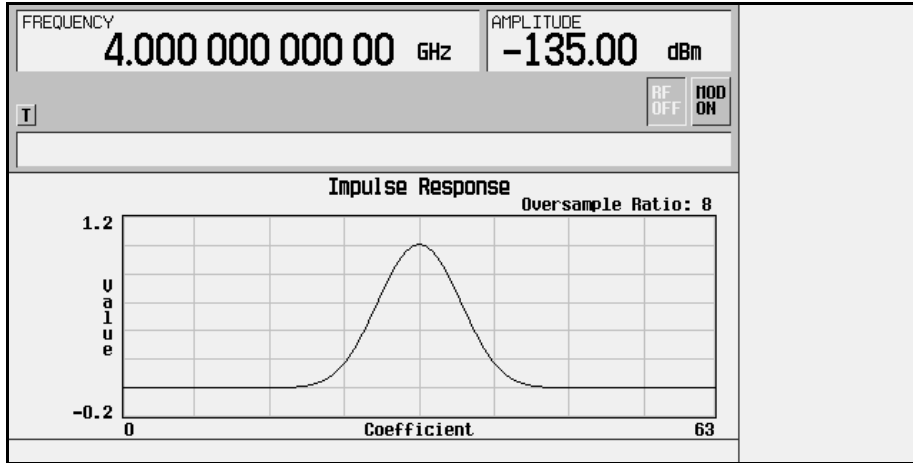

Modifying the Coefficients

Use the following procedure to modify the filter coefficients in the FIR filter table editor.

- Highlight coefficient 31.
- Press **0 > Enter** to change the value of the coefficient to 0.
- Press **Display Impulse Response** to see the effects of the change.

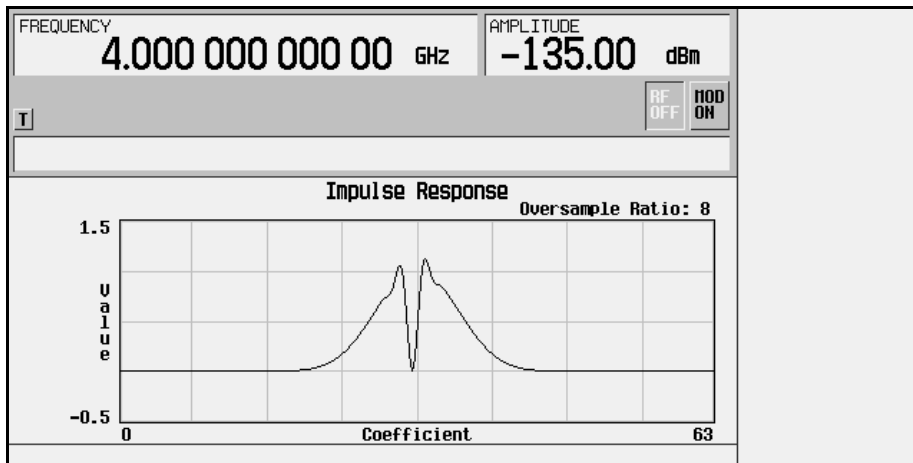

The graphic display can provide a useful troubleshooting tool (in this case, it indicates that a coefficient value is missing, resulting in an improper Gaussian response).

4. Press **Return** to return to the menu keys.
5. In addition to changing existing values, you can also insert and delete rows of coefficients and change the oversample ratio. (Press **More (2 of 2)** to access these softkeys.)
6. Highlight coefficient 31.
7. Press **1 > Enter**. This changes coefficient 31 back to its original value.

Storing the Filter to Memory

Use the following procedure to store the modified Gaussian filter to the signal generator's memory catalog.

1. Press **Load/Store > Store To File**. The catalog of FIR files is displayed along with the amount of memory available.
2. Name the file NEWFIR2.
3. Press **Enter** when the file name is complete. The contents of the current FIR table editor are stored to a file in non-volatile memory, and the catalog of FIR files is updated to show the new file.

Applying a User-Defined FIR Filter to a W-CDMA Waveform

Custom FIR filters can be created using the FIR table editor feature or they can be created externally and downloaded into the signal generator memory. Once the filter is stored in memory, it can be selected for use with your custom modulation state. This example requires that at least one FIR file be already stored in memory. For an example of creating and storing a FIR filter, see [“Creating a User-Defined FIR Filter Using the FIR Table Editor”](#) on page 2-31.

1. Press **Preset**.
2. Press **Mode > Arb Waveform Generator** (if it appears).
3. Press **CDMA Formats**.
4. Press **W-CDMA (3GPP 3.5 200103) > W-CDMA Define > Filter > Select > User FIR**. The catalog of FIR files should now be displayed. The following figure shows an example of the catalog.

| | | | | | |
|----------------------|-----------|-------------------|------|-------------------------|--|
| FREQUENCY | | AMPLITUDE | | Load From Selected File | |
| 4.000 000 000 00 GHz | | -135.00 dBm | | | |
| RF OFF | | MOD ON | | Store To File | |
| Catalog of FIR Files | | | | Delete File | |
| | | 227968 bytes used | | 47940 bytes free | |
| | File Name | Type | Size | Goto Row | |
| 1 | NEWFIR1 | FIR | 260 | Page Up | |
| 2 | NEWFIR2 | FIR | 516 | Page Down | |

In this example, there are two FIR files listed: NEWFIR1 and NEWFIR2. (These files were created in the previous examples.)

5. Scroll down in the list until the desired filter highlights. In this example, NEWFIR2 is the desired filter. You can use the front panel knob or the arrow keys as well as the GoTo Row function to highlight the filter.

6. Press **Select File**. The highlighted filter is now selected for use in your custom modulation state, as shown.

| | | | | |
|---|--|---------------------------------|--|---|
| FREQUENCY 4.000 000 000 00 GHz | | AMPLITUDE -135.00 dBm | | Select (NEWFIR2@FIR) → Define User FIR → Filter Factor N/A Optimize FIR For (N/A) Restore Default Filter |
| | | RF OFF MOD ON | | |
| WCDMA DL WCDMA Setup: 1 DPCH (Modified) Chip Rate: 3.840000Mcps Reconstruction: 2.500MHz Filter: User FIR Ref Freq: 10.000000MHz (Int) I/Q Mapping: Normal PRE Clip I+JQ : 100.0% | | | | |
| Off Link: Down Trig Type: Continuous Retrigger: On Trig Source: Ext Polarity: Neg Delay: Off | | | | |

The filter you selected is NEWFIR2. You can see the name, followed by @FIR, displayed below the **Select** softkey. In the Filter field, near the left of the display, User FIR is displayed to indicate that a user-defined FIR filter has been selected.

Once you have set the other modulation parameters to your satisfaction, turn on Custom and the RF output and your user-defined filter is in use.

NOTE

The actual oversample ratio during modulation is automatically selected by the instrument. A value between 4 and 16 is chosen dependent on the symbol rate, the number of bits per symbol of the modulation type, and the number of symbols.

3 Softkey Reference

This chapter describes the **Mode** hardkey and the associated softkeys used to configure and activate functions specific to the Option 100, W-CDMA (3GPP 3.5 200103) personality.

The softkeys are presented in alphabetical order.

Mode Key

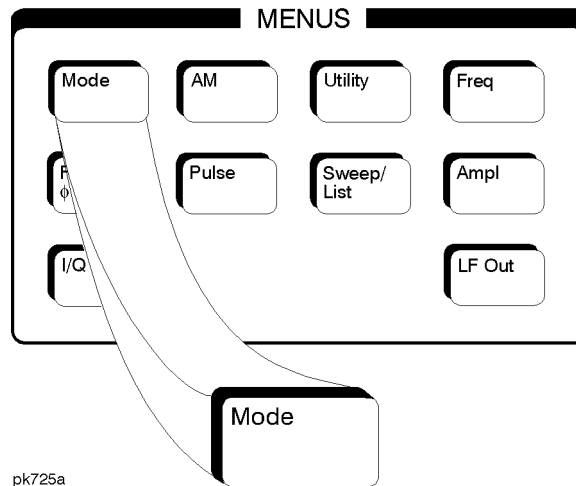

When you press the front-panel **Mode** key, the softkeys that appear depend on which options are included in the instrument. When an instrument has options in addition to the UND option, the softkey **Arb Waveform Generator** provides access to all Dual Arbitrary Waveform Generator softkeys (including the optional personalities).

The softkeys described in this chapter are available only under the **W-CDMA (3GPP 3.5 200103)** softkey.

For information on the SCPI commands that duplicate these softkeys remotely, see [Chapter 5, “Remote Programming,”](#) and [Chapter 6, “Programming Command Cross-Reference.”](#)

***n* ksps**

This key sets the symbol rate in kilo symbols per second (ksps). It is used for an inserted DPCH or OCNS downlink channel, for multiple channels in the W-CDMA Edit Channel Setup table editor, and for multiple uplink dedicated physical data channels (DPDCH). Where ***n* ksps** can be any of the following symbol rate softkeys:

| | |
|-----------------|-----------------|
| 7.5 ksps | 120 ksps |
| 15 ksps | 240 ksps |
| 30 ksps | 480 ksps |
| 60 ksps | 960 ksps |

Softkey Location (Downlink): **Mode > CDMA Formats > W-CDMA (3GPP 3.5 200103) > W-CDMA Define > Edit Channel Setup > Insert Row > DPCH, OCNS or Multiple Channels > Symbol Rate > *n* ksps**
(See description of *n* ksps.)

Softkey Location (Uplink): **Mode > CDMA Formats > W-CDMA (3GPP 3.5 200103) > W-CDMA Define > Edit Channel Setup > Insert DPDCH > Symbol Rate > *n* ksps** (See description of *n* ksps.)

1 DPCH

Selects a single DPCH channel for the W-CDMA downlink channel setup.

Softkey Location: **Mode > CDMA Formats > W-CDMA (3GPP 3.5 200103) > W-CDMA Select > 1 DPCH**

2

This softkey appears when you are editing a DPCH channel setup. Highlight a value in the **Pilot Bits** column of the Edit Channel Setup table editor and press the **Edit Item** softkey. Press the **2** softkey to select this value for the number of pilot bits.

NOTE

This softkey will only appear when the DPCH channel has a symbol rate of 15 ksps.

Softkey Location: **Mode > CDMA Formats > W-CDMA (3GPP 3.5 200103) > W-CDMA Define > Edit Channel Setup > Pilot Bits > Edit Item > 2**

2 Carriers

Selects a standard 2-carrier W-CDMA setup with the settings listed below. (See also “[W-CDMA Select](#)” on page 3-45.)

Carrier 1: PCCPCH + SCH, -7.5 MHz frequency offset,
0 dB power

Carrier 2: PCCPCH + SCH, 7.5 MHz frequency offset,
0 dB power

Softkey Location: **Mode > CDMA Formats > W-CDMA (3GPP 3.5 200103) > Multicarrier Off On > W-CDMA Select > 2 Carriers**

2.500 MHz

Selects a reconstruction filter with a cutoff frequency of 2.500 MHz.

Softkey Location: **Mode > CDMA Formats > W-CDMA (3GPP 3.5 200103) > CDMA Define > Reconstruction Filter > 2.500 MHz**

3 Carriers

Selects a standard 3-carrier W-CDMA setup with the settings listed below. (See also “[W-CDMA Select](#)” on page 3-45.)

Carrier 1: PCCPCH + SCH, -5 MHz frequency offset,
0 dB power

Carrier 2: PCCPCH + SCH, 0 kHz frequency offset,
0 dB power

Carrier 3: PCCPCH + SCH, 5 MHz frequency offset,
0 dB power

Softkey Location: **Mode > CDMA Formats > W-CDMA (3GPP 3.5 200103) > Multicarrier Off On > W-CDMA Select > 3 Carriers**

3 DPCH

Selects three DPCH channels for the W-CDMA downlink channel setup.

Softkey Location: **Mode > CDMA Formats > W-CDMA (3GPP 3.5 200103) > W-CDMA Select > 3 DPCH**

4

This softkey appears when you are editing a DPCH channel setup. Highlight a value in the `Pilot Bits` column of the `Edit Channel Setup` table editor and press the `Edit Item` softkey. Press the **4** softkey to select this value for the number of pilot bits.

NOTE

This softkey will only appear when the DPCH channel has a symbol rate of 15 ksps or 30 ksps.

Softkey Location: **Mode > CDMA Formats > W-CDMA (3GPP 3.5 200103) > W-CDMA Define > Edit Channel Setup > Pilot Bits > Edit Item > 4**

4 Carriers

Selects a standard 4-carrier W-CDMA setup with the settings listed below. (See also “[W-CDMA Select](#)” on page 3-45.)

Carrier 1: PCCPCH + SCH, -7.5 MHz frequency offset, 0 dB power

Carrier 2: PCCPCH + SCH, -2.5 MHz frequency offset, 0 dB power

Carrier 3: PCCPCH + SCH, 2.5 MHz frequency offset, 0 dB power

Carrier 4: PCCPCH + SCH, 7.5 MHz frequency offset, 0 dB power

Softkey Location: **Mode > CDMA Formats > W-CDMA (3GPP 3.5 200103) > Multicarrier Off On > W-CDMA Select > 4 Carriers**

8

This softkey appears when you are editing a DPCH channel setup. Highlight a value in the `Pilot Bits` column of the `Edit Channel Setup` table editor and press the `Edit Item` softkey. Press the **8** softkey to select this value for the number of pilot bits.

NOTE

This softkey will only appear when the DPCH channel has a symbol rate of 15 ksps or 30 ksps.

Softkey Location: **Mode > CDMA Formats > W-CDMA (3GPP 3.5 200103) > W-CDMA Define > Edit Channel Setup > Pilot Bits > Edit Item > 8**

8.000 MHz

Selects a reconstruction filter with a cutoff frequency of 8.000 MHz.

Softkey Location: **Mode > CDMA Formats > W-CDMA (3GPP 3.5 200103) > W-CDMA Define > Reconstruction Filter > 8.000 MHz**

250 kHz

Selects a reconstruction filter with a cutoff frequency of 250 kHz.

Softkey Location: **Mode > CDMA Formats > W-CDMA (3GPP 3.5 200103) > W-CDMA Define > Reconstruction Filter > 250.0 kHz**

Adjust Code Domain Power

Accesses a menu where you can adjust the code domain power (the relative power in each of the channels). Select **Equal Energy per Symbol** (all channels are of equal energy per bit and the total power equals 0 dB), or **Scale to 0 dB** (scale all of the current channel powers so that the total power equals 0 dB while keeping the previous relative power ratios between the individual channels). Available in Downlink only.

Softkey Location: **Mode > CDMA Formats > W-CDMA (3GPP 3.5 200103) > W-CDMA Define > Edit Channel Setup > Adjust Code Domain Power**

APCO 25 C4FM

Selects an APCO 25-specified C4FM filter in the Select (filter) menu for the current link. This is a Nyquist filter with an alpha of 0.2 which is combined with a shaping filter. This softkey is only available when **Multicarrier Off On** is toggled to **Off**.

Softkey Location: **Mode > CDMA Formats > W-CDMA (3GPP 3.5 200103) > W-CDMA Define > Filter > Select > APCO 25 C4FM**

Apply Channel Setup

Applies the changes made in the channel setup table editor (see [“Edit Channel Setup”](#) on page 3-15) for the current link. If the waveform is set to **On**, the new channel data generates a new modulation waveform in ARB waveform memory.

Softkey Location: **Mode > CDMA Formats > W-CDMA (3GPP 3.5 200103) > W-CDMA Define > Apply Channel Setup**

Apply Multicarrier

Applies the current settings in the multicarrier table editor. (See also [“Multicarrier Define”](#) on page 3-25.)

Softkey Location: **Mode > CDMA Formats > W-CDMA (3GPP 3.5 200103) > Multicarrier Off On > Multicarrier Define > Apply Multicarrier**

Apply To Waveform

Applies the current clipping settings you have selected to the waveform for the current link. Press **Return** if you do not want to apply the new settings at this time.

NOTE

The settings are applied the next time you generate a waveform.

Softkey Location: **Mode > CDMA Formats > W-CDMA (3GPP 3.5 200103) > W-CDMA Define > Clipping > Apply To Waveform**

ARB Reference Ext Int

Selects either an internal or an external reference for the waveform clock for the current link. If you choose external, you must enter the reference frequency (as described under the **Reference Frequency** softkey on [page 3-32](#)) and apply the signal to the BASEBAND GEN REF IN connector.

Default Value: Int39

Softkey Location: **Mode > CDMA Formats > W-CDMA (3GPP 3.5 200103) > W-CDMA Define > ARB Reference Ext Int**

Beta

This softkey is activated automatically when the Kaiser windowing function is selected. The default Beta factor provides a good compromise for optimizing out of band performance (ACP) without seriously compromising passband performance (EVM). Changing the Beta factor adjusts the trade-off between ACP and EVM. Decreasing the value improves EVM. Increasing the value improves ACP.

Range: 1.000 through 10.000

Default Value: 4.000

Softkey Location: **Mode > CDMA Formats > W-CDMA (3GPP 3.5 200103) > W-CDMA Define > Filter > Define User FIR > Load Default FIR > Root Nyquist (or Nyquist or Gaussian or Rectangle) > Window > Kaiser > Beta**

Bus

Sets the trigger source to bus. When the trigger source is set to bus, the signal generator triggers an event when it receives the appropriate command via GPIB.

Softkey Location: **Mode > CDMA Formats > W-CDMA (3GPP 3.5 200103) > Trigger > Trigger Setup > Trigger Source > Bus**

Channels

Press this softkey, then enter the number of duplicate channels that you want to set up and insert into the Edit Channel Setup table editor. Press the **Enter** softkey to terminate the entry.

After you have set the channel parameters, and the number of times you want the channel duplicated, press **Done** to insert the information into the table editor.

Downlink Range: 1 through 511

Uplink Range: 1 through 6

Default Value: 1

Softkey Location (Downlink): **Mode > CDMA Formats > W-CDMA (3GPP 3.5 200103) > W-CDMA Define > Edit Channel Setup > Insert Row > Multiple Channels > Channels**

Softkey Location (Uplink): **Mode > CDMA Formats > W-CDMA (3GPP 3.5 200103) > Link Down Up > W-CDMA Define > Edit Channel Setup > Insert DPDCH > Channels**

Chip Rate

Displays a menu where you can choose the chip rate for the channels in the current table editor.

Range: $\pm 10\%$

Default Value: 3.840000 Mcps

Softkey Location: **Mode > CDMA Formats > W-CDMA (3GPP 3.5 200103) > W-CDMA Define > Edit Channel Setup > Chip Rate**

Clip |I+jQ| To

Use this softkey to make the modulation level of the combined I and Q waveform the active function for the current link. You can then clip (limit) the level to a percentage of full scale. A level of 100.0% equates to no clipping.

Range: 10.0 through 100.0%, in 0.1% increments

Default Value: 100.0%

Softkey Location: **Mode > CDMA Formats > W-CDMA (3GPP 3.5 200103) > W-CDMA Define > Clipping > Clip |I+jQ| To**

Clip |I| To

Use this softkey to make the modulation level of the I component the active function for the current link. You can then clip (limit) the level to a percentage of full scale. A level of 100.0% equates to no clipping.

Range: 10.0 through 100.0%, in 0.1% increments

Default Value: 100.0%

Softkey Location: **Mode > CDMA Formats > W-CDMA (3GPP 3.5 200103) > W-CDMA Define > Clipping > Clip |I| To**

Clip |Q| To

Use this softkey to make the modulation level of the Q component the active function for the current link. You can then clip (limit) the level to a percentage of full scale. A level of 100.0% equates to no clipping.

Range: 10.0 through 100.0% in 0.1% increments

Default Value: 100.0%

Softkey Location: **Mode > CDMA Formats > W-CDMA (3GPP 3.5 200103) > W-CDMA Define > Clipping > Clip |Q| To**

Clip At PRE POST FIR Filter

Use this softkey to select whether you want the waveform clipped before (PRE) or after (POST) FIR filtering for the current link.

Default Value: PRE

Softkey Location: **Mode > CDMA Formats > W-CDMA (3GPP 3.5 200103) > W-CDMA Define > Clipping > Clip At PRE POST FIR Filter**

Clipping

Accesses a menu of options for limiting the modulation level for the current link.

Softkey Location: **Mode > CDMA Formats > W-CDMA (3GPP 3.5 200103) > W-CDMA Define > Clipping**

Clipping Type $|I+jQ|$ $|I|,|Q|$

Use this softkey to select either $|I+jQ|$ or $|I|,|Q|$ as the clipping type for the current link. If you select $|I+jQ|$, the combined I and Q waveform is clipped (*circular* clipping). If you select $|I|,|Q|$, the I and Q components of the waveform are clipped independently (*rectangular* clipping). In this case, you can clip I and Q to different levels.

Default Value: $|I+jQ|$

Softkey Location: **Mode > CDMA Formats > W-CDMA (3GPP 3.5 200103) > W-CDMA Define > Clipping > Clipping Type $|I+jQ|$ $|I|,|Q|$**

Continuous

Sets the W-CDMA trigger type to continuous for the current link. In continuous trigger mode, the waveform repeats itself indefinitely.

Softkey Location: **Mode > CDMA Formats > W-CDMA (3GPP 3.5 200103) > Trigger > Continuous**

CPICH

Inserts a CPICH channel into the downlink Edit Channel Setup table editor.

Softkey Location: **Mode > CDMA Formats > W-CDMA (3GPP 3.5 200103) > W-CDMA Define > Edit Channel Setup > Insert Row > CPICH**

Custom W-CDMA Carrier

Displays the downlink W-CDMA (DWCDMA) memory catalog. From this catalog listing, you can choose a previously stored custom carrier setup.

Softkey Location: **Mode > CDMA Formats > W-CDMA (3GPP 3.5 200103) > Multicarrier Off On > Multicarrier Define > Edit Item (or Insert Row) > Custom W-CDMA Carrier**

Custom W-CDMA Multicarrier

Displays the multicarrier downlink W-CDMA (MDWCDMA) memory catalog. From this catalog listing, you can choose a previously stored custom multicarrier setup.

Softkey Location: **Mode > CDMA Formats > W-CDMA (3GPP 3.5 200103) > Multicarrier Off On > W-CDMA Select > Custom W-CDMA Multicarrier**

Custom W-CDMA State

Displays the W-CDMA Setup Select File menu for the current link, where you can choose a previously stored custom W-CDMA setup.

Softkey Location: **Mode > CDMA Formats > W-CDMA (3GPP 3.5 200103) > W-CDMA Select > Custom W-CDMA State**

Define User FIR

Accesses a table editor where you can create and modify FIR filters for the current link. The FIR table editor allows a maximum filter length of 1024 coefficients with a maximum oversampling ratio of 32. An FIR filter selected for use in W-CDMA, however, cannot have more than 512 coefficients so the number of symbols and the oversample ratio should be selected accordingly. Examples of using the FIR table editor are provided in the “Using Functions” chapter.

Softkey Location: **Mode > CDMA Formats > W-CDMA (3GPP 3.5 200103) > W-CDMA Define > Filter > Define User FIR**

Delete All Rows

Deletes all rows in the current table editor.

CAUTION Deletions cannot be recovered.

Delete All Rows is located in table editors.

Delete File

Deletes the highlighted file from the displayed catalog. You will be prompted for confirmation.

Delete File is located in catalogs of files.

Delete Row

Deletes the highlighted row in the current table editor.

CAUTION Deletions cannot be recovered.

Softkey Location: **Mode > CDMA Formats > W-CDMA (3GPP 3.5 200103) > W-CDMA Define > Edit Channel Setup > Delete Row**

Display Code Domain Power

Displays a graphical representation of the code domain power. Power (in decibels) is represented on the y-axis and the code domain space is represented on the x-axis.

The display represents the code domain power as a graph of the relationship between power in each channel (–40 to 0 dB) versus code domain space (0 to highest code used in setup). Total code domain power is displayed above the graph.

The following is an example of a Code Domain Power graph.

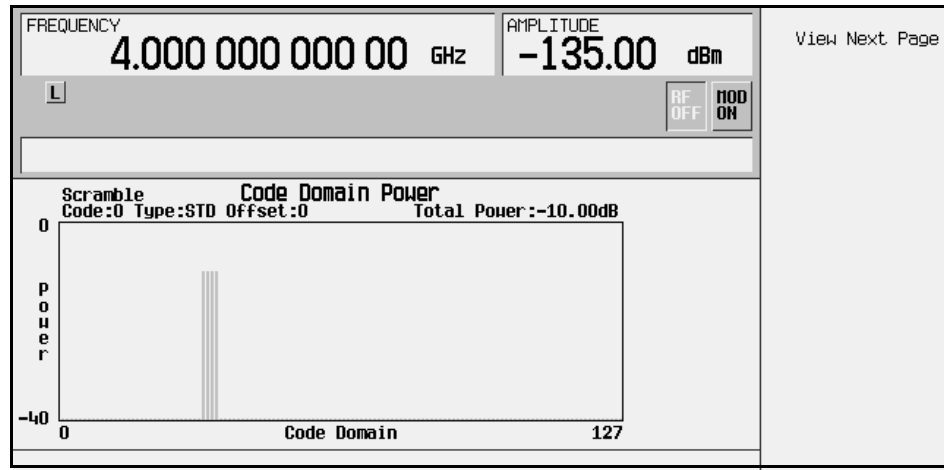

To view additional code domain space, press **View Next Page**. To return to the start press **View Next Page** until you cycle through the entire code domain space and return to the display of code domain 0—127.

When the data contains more than one combination of the scramble code, scramble type, or scramble offset, pressing the **Display Code Domain Power** softkey will open a menu where you can select to **View Next Page**, or choose to display the **Previous Scramble Code** or the **Next Scramble Code**.

The following is an example of the Code Domain Power graph display with the additional softkeys.

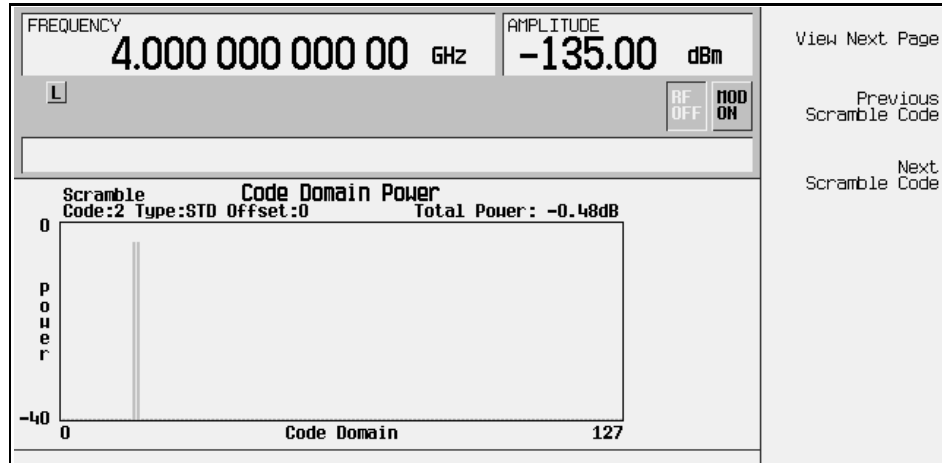

To return to the table editor and the menu keys press **Return**.

Softkey Location: **Mode > CDMA Formats > W-CDMA(3GPP 3.5 200103) > W-CDMA Define > Edit Channel Setup > Display Code Domain Power**

Display FFT

Displays a graphical representation of the frequency response of the filter loaded into the FIR table editor (calculated using a fast Fourier transform) for the current link. The following is an example of the frequency response of a root Nyquist filter with an oversample ratio of 4.

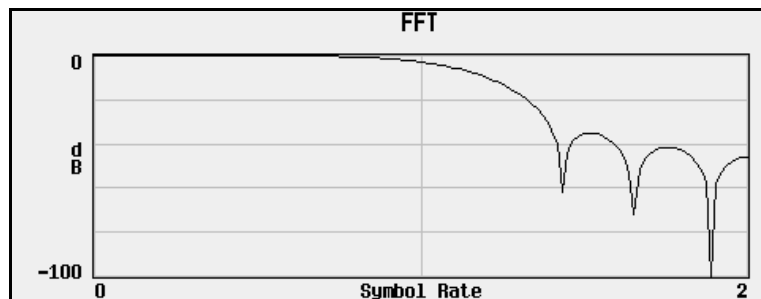

To return to the FIR table editor and the menu keys, press **Return**.

Softkey Location: **Mode > CDMA Formats > W-CDMA (3GPP 3.5 200103) > W-CDMA Define > Filter > Define User FIR > Display FFT**

Display Impulse Response

Displays a graphical representation of impulse response in time of the filter loaded into the FIR table editor for the current link. The following is an example of the impulse response of a root Nyquist filter with an oversample ratio of 4.

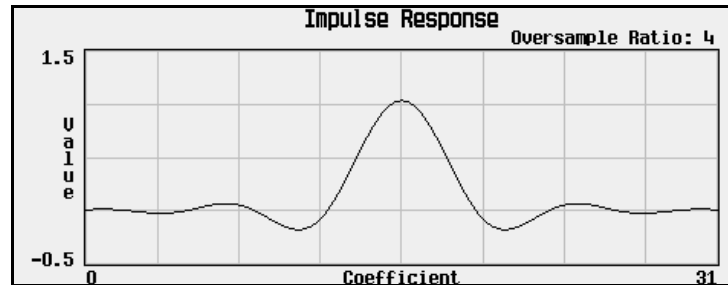

To return to the FIR table editor and the menu keys, press **Return**.

Softkey Location: **Mode > CDMA Formats > W-CDMA (3GPP 3.5 200103) > W-CDMA Define > Filter > Define User FIR > Display Impulse Response**

DPCCH

Selects a single DPCCH channel for the W-CDMA uplink channel setup.

Softkey Location: **Mode > CDMA Formats > W-CDMA (3GPP 3.5 200103) > Link Down Up > W-CDMA Select > DPCCH**

DPCCH + 1 DPDCH

Selects a DPCCH plus one DPDCH channel for the W-CDMA uplink channel setup.

Softkey Location: **Mode > CDMA Formats > W-CDMA (3GPP 3.5 200103) > Link Down Up > W-CDMA Select > DPCCH + 1 DPDCH**

DPCCH + 2 DPDCH

Selects a DPCCH plus two DPDCH channels for the W-CDMA uplink channel setup.

Softkey Location: **Mode > CDMA Formats > W-CDMA (3GPP 3.5 200103) > Link Down Up > W-CDMA Select > DPCCH + 2 DPDCH**

DPCCH + 3 DPDCH

Selects a DPCCH plus three DPDCH channels for the W-CDMA uplink channel setup.

Softkey Location: **Mode** > **CDMA Formats** > **W-CDMA (3GPP 3.5 200103)** >
Link Down Up > **W-CDMA Select** > **DPCCH + 3 DPDCH**

DPCCH + 4 DPDCH

Selects a DPCCH plus four DPDCH channels for the W-CDMA uplink channel setup.

Softkey Location: **Mode** > **CDMA Formats** > **W-CDMA (3GPP 3.5 200103)** >
Link Down Up > **W-CDMA Select** > **DPCCH + 4 DPDCH**

DPCCH + 5 DPDCH

Selects a DPCCH plus five DPDCH channels for the W-CDMA uplink channel setup.

Softkey Location: **Mode** > **CDMA Formats** > **W-CDMA (3GPP 3.5 200103)** >
Link Down Up > **W-CDMA Select** > **DPCCH + 5 DPDCH**

DPCH

Displays a menu where you can choose the symbol rate (in ksps) of the DPCH channel that is then inserted into the downlink Edit Channel Setup table editor.

Softkey Location: **Mode** > **CDMA Formats** > **W-CDMA (3GPP 3.5 200103)** >
W-CDMA Define > **Edit Channel Setup** > **Insert Row** > **DPCH**

Edit Channel Setup

Accesses a table editor where you can define the channel parameters of the current W-CDMA signal for the current link.

Use the front-panel knob or the arrow keys to move the cursor within the table structure, and the numeric keypad to change values contained in the table.

NOTE

Using the keys found beneath the **Goto Row** softkey, you can move more quickly through a large table.

Softkey Location: **Mode** > **CDMA Formats** > **W-CDMA (3GPP 3.5 200103)** >
W-CDMA Define > **Edit Channel Setup**

Edit Item

Press this softkey to change the highlighted item in the displayed table.

Edit Item is located in the table editor menus.

Equal Energy per Symbol

Sets the selected channel powers to equal energy per symbol (referenced to 7.5 kbps, and increasing by 3 dB for each doubling of the symbol rate). Available in downlink only.

Softkey Location: **Mode > CDMA Formats > W-CDMA (3GPP 3.5 200103) > W-CDMA Define > Edit Channel Setup > Adjust Code Domain Power > Equal Energy per Symbol**

Ext

Sets the trigger source to external triggering. When the trigger source is set to external, the signal generator will trigger an event when it receives the appropriate signal via the PATTERN TRIG IN connector.

Softkey Location: **Mode > CDMA Formats > W-CDMA (3GPP 3.5 200103) > Trigger > Trigger Setup > Trigger Source > Ext**

Ext Delay Off On

Arms (On) or disarms (Off) the external trigger delay for the current link. To use external trigger delay, press this softkey until **Ext Delay On** is highlighted, and then set the external delay time by pressing the **Ext Delay Time** softkey.

Default Value: Off

Softkey Location: **Mode > CDMA Formats > W-CDMA (3GPP 3.5 200103) > Trigger > Trigger Setup > Trigger Source > Ext Delay Off On**

Ext Delay Time

Sets the time for the external trigger delay. External trigger delay may be adjusted to trigger a waveform at a specified length of time after an external trigger signal has been received at the PATTERN TRIG IN connector. Enter a new value and press the **Enter** terminator softkey.

To use external trigger delay, press **Ext Delay Off On** until **On** is highlighted, and then set the external delay time by pressing the **Ext Delay Time** softkey.

Range: 2.0 microseconds through 3600 seconds.

Default Value: 2.000 milliseconds

Softkey Location: **Mode > CDMA Formats > W-CDMA (3GPP 3.5 200103) > Trigger > Trigger Setup > Trigger Source > Ext Delay Time**

Ext Polarity Neg Pos

Sets the external trigger source polarity to either a positive change or a negative change in signal level. Depending on your choice, the signal generator will trigger an event when it receives the appropriate positive or negative change in signal at the PATTERN TRIG IN connector.

Default Value: Neg

Softkey Location: **Mode > CDMA Formats > W-CDMA (3GPP 3.5 200103) > Trigger > Trigger Setup > Trigger Source > Ext Polarity Neg Pos**

Filter

Accesses menus where you can select a filter type, restore the default filter, or define a unique FIR filter for the current link. The Filter menu also lets you adjust the filter alpha (when Nyquist or root Nyquist filters are selected) or bandwidth time product (for Gaussian filters).

Softkey Location: **Mode > CDMA Formats > W-CDMA (3GPP 3.5 200103) > W-CDMA Define > Filter**

Filter Alpha

Press this softkey to change the FIR filter's alpha parameter in either the Filter menu or the Load Default FIR menus.

In the Filter Menu

Changes the alpha parameter of the selected root Nyquist or Nyquist filter. To enter a new value, rotate the front-panel knob until the desired value is displayed, use the up and down arrow keys, or enter the value using the numeric keypad and press the **Enter** terminator softkey.

This key only appears *after* choosing a root Nyquist or Nyquist filter. If a Gaussian filter is in use, you will see **Filter BbT**. If any other filter is in use, you will see a grayed-out softkey: **Filter Factor N/A**.

Range: 0.000 through 1.000

Default Value: 0.500

Softkey Location: **Mode > CDMA Formats > W-CDMA (3GPP 3.5 200103) > W-CDMA Define > Filter > Filter Alpha**

In the Load Default FIR Menu

Restores the default alpha parameter of the root Nyquist or Nyquist filter coefficients loaded into the FIR table editor. After entering the alpha value, press **Generate** to modify the filter coefficients in the table editor.

Default Value: 0.350

Softkey Location: **Mode > CDMA Formats > W-CDMA (3GPP 3.5 200103) > W-CDMA Define > Filter > Define User FIR > Load Default FIR > Root Nyquist (or Nyquist) > Filter Alpha**

Filter BbT

Changes the bandwidth-multiplied-by-bit-time (BbT) filter parameter in either the Filter menu or the Load Default FIR menu.

In the Filter Menu

In the Filter menu, **Filter Bbt** changes the BbT parameter of the selected Gaussian filter.

NOTE

This key appears only *after* choosing a Gaussian filter. If a root Nyquist or Nyquist filter is in use, you will see **Filter Alpha**. If any other filter is in use, you will see a **Filter Factor N/A** softkey (grayed-out).

Range: 0.000 through 1.000

Default Value: 0.500

Softkey Location: **Mode > CDMA Formats > W-CDMA (3GPP 3.5 200103) > W-CDMA Define > Filter > Select > Gaussian > Filter BbT**

In the Load Default FIR Menu

Restores the default BbT parameter of the Gaussian filter coefficients loaded into the FIR table editor. After entering the BbT value, press **Generate** to modify the filter coefficients in the table editor.

This is a persistent state that is set to 0.300 at the factory.

Softkey Location: **Mode > CDMA Formats > W-CDMA (3GPP 3.5 200103) > W-CDMA Define > Filter > Define User FIR > Load Default FIR > Gaussian > Filter BbT**

Filter Factor

This grayed-out softkey is displayed when the filter in use does not contain an adjustable alpha or BbT parameter (such as the IS-95 filter selections or a user-defined FIR filter). This softkey changes to **Filter Alpha** when root Nyquist or Nyquist is selected, and **Filter BbT** when Gaussian is selected.

Softkey Location: **Mode > CDMA Formats > W-CDMA (3GPP 3.5 200103) > W-CDMA Define > Filter > Filter Factor**

Filter Symbols

Defines the number of symbols for the filter to be loaded into the FIR table editor. Although the FIR table editor allows a maximum of 32 symbols, 1024 coefficients with a maximum oversample ratio of 32, a FIR filter selected for use in W-CDMA cannot have more than 512 coefficients. Therefore, the number of symbols and the oversample ratio should be selected accordingly.

To change the number of symbols, rotate the front-panel knob until the desired value is displayed, use the up and down arrow keys, or enter the value using the numeric keypad and press the **Enter** terminator softkey.

Range: 1 through 32

Default Value: 8

Softkey Location: **Mode > CDMA Formats > W-CDMA (3GPP 3.5 200103) > W-CDMA Define > Filter > Define User FIR > Load Default FIR > Root Nyquist (or Nyquist or Gaussian or Rectangle) > Filter Symbols**

First Spread Code

This softkey appears in the Edit Channel Setup table editors, where you define a channel and then insert multiple entries of that channel into the table editor.

Press the **First Spread Code** softkey, then enter the value that you want for the starting spread code for the channels that will be inserted. Press the softkey **Enter** to terminate the entry.

NOTE

Check existing entries in the table editor to be sure that there will be no duplication of an existing spread code. If there is, the warning **Domain Conflict** is displayed in the table. If this happens, select any duplicate **Spread Code** entries and give them unique values.

After you have set the channel parameters, and the number of times you want the channel duplicated, press **Done** to insert the information into the table editor.

Range: 0 through 15

Default Value: 8

Softkey Location: **Mode > CDMA Formats > W-CDMA (3GPP 3.5 200103) > W-CDMA Define > Edit Channel Setup > Insert Row > Multiple Channels > First Spread Code**

Or: **Mode > CDMA Formats > W-CDMA (3GPP 3.5 200103) > Link Down Up > W-CDMA Define > Edit Channel Setup > Insert DPDCH > First Spread Code**

Gain Unit dB Lin Index

This softkey toggles the units for the uplink channel power among dB, linear ratio, and signaling index. When either dB or linear ratio is selected, arbitrary power levels may be entered. If signaling index is selected, only integers from 0 to 15 can be entered.

Softkey Location: **Mode > CDMA Formats > W-CDMA (3GPP 3.5 200103) > Link Down Up > W-CDMA Define > Edit Channel Setup > Gain Unit dB Lin Index**

Gate Active

This softkey remains grayed-out until the trigger is set to Gated. Once the trigger has been set, press **Gate Active Low High** to toggle the polarity of the “through” or active state of a gated trigger signal. Gate Active Low will output the signal while the gate is low at the PATTERN TRIG IN connector. Gate Active High has the opposite effect, outputting the signal while the signal level at the PATTERN TRIG IN connector is in a high state.

Softkey Location: **Mode > CDMA Formats > W-CDMA (3GPP 3.5 200103) > Trigger > Trigger Setup > Gate Active**

Gated

Sets the trigger type to Gated. Using a gated trigger, you can set the signal to output when a TTL high or low is present at the PATTERN TRIG IN connector. To set the gate to trigger on either high or low, press **Gated > Trigger Setup > Gate Active Low High**.

Softkey Location: **Mode > CDMA Formats > W-CDMA (3GPP 3.5 200103) > Trigger > Gated**

Gaussian

Selects the Gaussian pre-modulation filter for the current link in either the Select (filter) menu or the Load Default FIR menu.

In the Select (Filter) Menu

Selects this FIR filter for use in your filter setup. Use the **Filter BbT** softkey to change the filter bandwidth-multiplied-by-bit-time product value.

Range: 0.000 through 1.000

Default Value: 0.500

Softkey Location: **Mode > CDMA Formats > W-CDMA (3GPP 3.5 200103) > W-CDMA Define > Filter > Select > Gaussian**

In the Load Default FIR Menu

Pressing the **Gaussian** softkey followed by **Generate** loads the FIR table editor with the coefficient values for the Gaussian filter. The filter BbT and number of filter symbols are defined with the softkeys in this menu. If you change either parameter after loading the filter coefficients, press the **Generate** softkey again to reload the FIR table.

The **Display Impulse Response** and **Display FFT** softkeys in this menu graphically display the filter as it is currently defined in the FIR table editor.

Softkey Location: **Mode > CDMA Formats > W-CDMA (3GPP 3.5 200103) > W-CDMA Define > Filter > Define User FIR > Load Default FIR > Gaussian**

Goto Bottom Row

Moves the selection bar to the bottom row in the current table editor or list of items.

Goto Bottom Row is located in table editor menus and in catalogs of files.

Goto Middle Row

Moves the selection bar to the middle row in the current table editor or list of items.

Goto Middle Row is located in table editor menus and in catalogs of files.

Goto Row

Displays softkeys that enable you to select a row or page in a table or list of items.

Goto Row is located in table editor menus and in catalogs of files.

Goto Top Row

Moves the selection bar to the top row in the current table or list of items.

Goto Top Row is located in table editor menus and in catalogs of files.

Hamming

Press this softkey to apply the Hamming windowing function to the selected filter. Windowing can be applied to any default FIR filter that you load into the Define User FIR table. Windowing improves out of band performance (ACP) by smoothing the filter's transition to zero, but simultaneously degrades passband performance (EVM).

Softkey Location: **Mode > CDMA Formats > W-CDMA (3GPP 3.5 200103) > W-CDMA Define > Filter > Define User FIR > Load Default FIR > Root Nyquist (or Nyquist or Gaussian or Rectangle) > Window> Hamming**

Hann

Press this softkey to apply the Hann windowing function to the selected filter. Windowing can be applied to any default FIR filter that you load into the Define User FIR table. Windowing improves out of band performance (ACP) by smoothing the filter's transition to zero, but simultaneously degrades passband performance (EVM).

Softkey Location: **Mode > CDMA Formats > W-CDMA (3GPP 3.5 200103) > W-CDMA Define > Filter > Define User FIR > Load Default FIR > Root Nyquist (or Nyquist or Gaussian or Rectangle) > Window> Hann**

I/Q Mapping Normal Invert

Selects whether the I/Q outputs for the current link will be normal or inverted.

Default Value: Normal

Softkey Location: **Mode > CDMA Formats > W-CDMA (3GPP 3.5 200103) > W-CDMA Define > I/Q Mapping Normal Invert**

Insert DPDCH

Accesses a menu where you can set up and insert one or more DPDCH channels into the uplink Edit Channel Setup table editor. The maximum number of DPDCH channels allowed is six.

NOTE

You must position the selection bar below the DPCCH channel in the table editor and press **Done** to insert channels.

Softkey Location: **Mode > CDMA Formats > W-CDMA (3GPP 3.5 200103) > Link Down Up > W-CDMA Define > Edit Channel Setup > Insert DPDCH**

Insert Row

Displays a menu where you can select the type of row you wish to insert into the current table editor.

Softkey Location: **Mode > CDMA Formats > W-CDMA (3GPP 3.5 200103) > W-CDMA Define > Edit Channel Setup > Insert Row**

IS-2000 SR3 DS

Selects the standard IS-2000 spreading rate 3 direct spread filter.

Softkey Location: **Mode** > **CDMA Formats** > **W-CDMA (3GPP 3.5 200103)** > **W-CDMA Define** > **Filter** > **Select** > **IS-95 and IS-2000** > **IS-2000 SR3 DS**

IS-95

Selects the standard IS-95 baseband filter.

Softkey Location: **Mode** > **CDMA Formats** > **W-CDMA (3GPP 3.5 200103)** > **W-CDMA Define** > **Filter** > **Select** > **IS-95 and IS-2000** > **IS-95**

IS-95 and IS-2000

Press this softkey to open a menu of IS-95 and IS-2000 filters in the Select Filter menu. This menu displays the following IS-95 and IS-2000 filter choices: IS-95, IS-95 w/EQ, IS-95 Mod, IS-95 Mod w/EQ and IS-2000 SR3 DS.

Softkey Location: **Mode** > **CDMA Formats** > **W-CDMA (3GPP 3.5 200103)** > **W-CDMA Define** > **Filter** > **Select** > **IS-95 and IS-2000**

IS-95 Mod

Selects a modified version of the standard IS-95 baseband filter. This filter is modified for improved adjacent channel power performance. The modification, however, is done in a manner that still meets the IS-95 error function criterion.

Softkey Location: **Mode** > **CDMA Formats** > **W-CDMA (3GPP 3.5 200103)** > **W-CDMA Define** > **Filter** > **Select** > **IS-95 and IS-2000** > **IS-95 Mod**

IS-95 Mod w/EQ

Selects a modified version of the standard IS-95 baseband filter. This filter is modified for improved adjacent channel power performance, and includes the equalizer specified by IS-95. The filter modification is done in a manner that still meets the IS-95 error function criterion.

Softkey Location: **Mode** > **CDMA Formats** > **W-CDMA (3GPP 3.5 200103)** > **W-CDMA Define** > **Filter** > **Select** > **IS-95 and IS-2000** > **IS-95 Mod w/EQ**

IS-95 w/EQ

Selects the standard IS-95 baseband filter with an equalizer provided for phase compensation required by the base station.

Softkey Location: **Mode** > **CDMA Formats** > **W-CDMA (3GPP 3.5 200103)** > **W-CDMA Define** > **Filter** > **Select** > **IS-95 and IS-2000** > **IS-95 w/EQ**

Kaiser

Press this softkey to apply the Kaiser windowing function to the selected filter. Windowing can be applied to any default FIR filter that you load into the Define User FIR table. Windowing improves out of band performance (ACP) by smoothing the filter's transition to zero, but simultaneously degrades passband performance (EVM). Selecting **Kaiser** also activates the Beta factor which you adjust to change the trade-off between optimized ACP or EVM. Decreasing the value improves EVM. Increasing the value improves ACP.

Softkey Location: **Mode > CDMA Formats > W-CDMA (3GPP 3.5 200103) > W-CDMA Define > Filter > Define User FIR > Load Default FIR > Root Nyquist (or Nyquist or Gaussian or Rectangle) > Window > Kaiser**

Left Alternate

Sets the downlink channel scramble type to left alternate. Selecting **Left Alternate** adds 8192 to the scramble code.

Softkey Location: **Mode > CDMA Formats > W-CDMA (3GPP 3.5 200103) > W-CDMA Define > Edit Channel Setup > Modify All Scramble Codes > Scramble Type > Left Alternate**

Or: **Mode > CDMA Formats > W-CDMA (3GPP 3.5 200103) > W-CDMA Define > Edit Channel Setup > insert Rows > Multiple Channels > Scramble > Scramble Type > Left Alternate**

Link Down Up

Selects a W-CDMA downlink or uplink channel configuration.

Downlink = base to mobile

Uplink = mobile to base

Default Value: Downlink

Softkey Location: **Mode > CDMA Formats > W-CDMA (3GPP 3.5 200103) > Link Down Up**

Load Default FIR

Accesses a menu where you can automatically fill the current FIR table editor with coefficient values from pre-defined filters such as root Nyquist, Nyquist, Gaussian, and Rectangle. The default filter parameters can also be selected in this menu allowing you to choose the filter alpha or BbT and the number of filter symbols.

Softkey Location: **Mode > CDMA Formats > W-CDMA (3GPP 3.5 200103) > W-CDMA Define > Filter > Define User FIR > Load Default FIR**

Load From Selected File

Replaces the current information in a table editor with the information stored in the highlighted file.

Load From Selected File is located in catalogs of files.

Load/Store

Accesses a menu where you can load the current table editor with values from files previously stored in the signal generator memory, save data to a file, or delete a file.

Softkey Location: **Mode > CDMA Formats > W-CDMA (3GPP 3.5 200103) > W-CDMA Define > Filter > Define User FIR > Load/Store**

Mirror Table

Mirrors the current FIR table entries such that the table doubles in size, and the values in the top half of the table are duplicated in the bottom half of the table in reverse order.

Softkey Location: **Mode > CDMA Formats > W-CDMA (3GPP 3.5 200103) > W-CDMA Define > Filter > Define User FIR > Mirror Table**

Modify All Scramble Codes

Accesses a menu where you can select the Scramble Code, Scramble Type, and the Scramble Offset of all channels in the downlink Edit Channel Setup table editor.

After you enter the desired values, press the **Done** softkey to change all of the scramble codes to the new values.

Softkey Location: **Mode > CDMA Formats > W-CDMA (3GPP 3.5 200103) > W-CDMA Define > Edit Channel Setup > Modify All Scramble Codes**

Multicarrier Define

Accesses the Multicarrier W-CDMA Setup table, where you can define a multicarrier W-CDMA signal. This softkey is not present in the softkey menu until multicarrier mode is enabled (see [“Multicarrier Off On”](#) on page 3-26).

For information on using W-CDMA multicarrier, refer to [“Creating, Storing, & Recalling a Custom Multicarrier W-CDMA Waveform”](#) on page 2-22.

Softkey Location: **Mode > CDMA Formats > W-CDMA (3GPP 3.5 200103) > Multicarrier Off On > Multicarrier Define**

Multicarrier Off On

Toggles the multicarrier mode off and on.

When Multicarrier is on, the **W-CDMA Define** softkey becomes the **Multicarrier Define** softkey. Also, the options under the **W-CDMA Select** softkey change (see “[W-CDMA Select](#)” on page 3-45).

For information on using multicarrier W-CDMA, refer to “[Creating, Storing, & Recalling a Custom Multicarrier W-CDMA Waveform](#)” on page 2-22.

NOTE

The **Multicarrier Off On** softkey and related functions are accessible *only* when using the W-CDMA downlink setup.

Default Value: Off

Softkey Location: **Mode > CDMA Formats > W-CDMA (3GPP 3.5 200103) > Multicarrier Off On**

Multiple Channels

Displays a menu where you can set up one or more identical channels to insert into the downlink Edit Channel Setup table editor. After you have set the channel parameters, and how many times you want the channel duplicated, press **Done** to insert the information into the table editor.

Softkey Location: **Mode > CDMA Formats > W-CDMA (3GPP 3.5 200103) > W-CDMA Define > Edit Channel Setup > Insert Row > Multiple Channels**

Next Scramble Code

Displays the code domain power graph of the next channel when there is more than one combination of scramble code, scramble type, or scramble offset.

Softkey Location: **Mode > CDMA Formats > W-CDMA(3GPP 3.5 200103) > W-CDMA Define > Edit Channel Setup > Display Code Domain Power > Next Scramble Code**

None

Selects no windowing for the selected filter in the current link. The filter is optimized for maximum passband performance (EVM).

Softkey Location: **Mode > CDMA Formats > W-CDMA (3GPP 3.5 200103) > W-CDMA Define > Filter > Define User FIR > Load Default FIR > Root Nyquist (or Nyquist or Gaussian or Rectangle) > Window > None**

Nyquist

Selects the Nyquist (raised cosine) pre-modulation filter for the current link in either the Select (filter) menu or the Load Default FIR menu.

In the Select (Filter) Menu

Pressing the **Nyquist** softkey selects this FIR filter for use in the filter setup.

Range: 0 through 1

Default Filter Alpha: 0.220

Softkey Location: **Mode > CDMA Formats > W-CDMA (3GPP 3.5 200103) > W-CDMA Define > Filter > Select > Nyquist**

In the Load Default FIR Menu

Pressing the **Nyquist** softkey followed by **Generate** loads the FIR table editor with the coefficient values for the Nyquist filter. The filter alpha and number of filter symbols are defined with the softkeys in this menu. If you change either parameter after loading the filter coefficients, press the **Generate** softkey again to reload the FIR table. The **Display Impulse Response** and **Display FFT** softkeys in this menu graphically display the filter as it is currently defined in the FIR table editor.

Softkey Location: **Mode > CDMA Formats > W-CDMA (3GPP 3.5 200103) > W-CDMA Define > Filter > Define User FIR > Load Default FIR > Nyquist**

OCNS

Orthogonal Channel Noise Source sets all symbols for the channel being inserted to random values, instead of having specific bit fields. Press **OCNS** to display a menu where you can choose the symbol rate (in kbps) of the OCNS channel that is then inserted into the downlink Edit Channel Setup table editor.

Softkey Location: **Mode > CDMA Formats > W-CDMA (3GPP 3.5 200103) > W-CDMA Define > Edit Channel Setup > Insert Row > OCNS**

Optimize FIR For EVM ACP

Optimizes the filter for minimized error vector magnitude (select EVM) or for minimized adjacent channel power (select ACP). The EVM selection provides the most ideal pass band. The ACP selection improves stopband rejection. This feature only applies to root Nyquist, Nyquist, and Gaussian filters. The softkey is grayed out when any other filter is selected.

Default Value: EVM

Softkey Location: **Mode > CDMA Formats > W-CDMA (3GPP 3.5 200103) > W-CDMA Define > Filter > Optimize FIR For EVM ACP**

Oversample Ratio

Sets the oversampling ratio to be applied to a custom FIR filter design in the Define User FIR menu for the current link. Although the FIR table editor allows a maximum oversample ratio of 32, 1024 coefficients with a maximum of 32 symbols, a FIR filter selected for use in W-CDMA cannot have more than 512 coefficients. Therefore, the oversample ratio and the number of symbols should be selected accordingly.

This is a persistent state that is set to 4 at the factory.

Range: 1 through 32

Softkey Location: **Mode > CDMA Formats > W-CDMA (3GPP 3.5 200103) > W-CDMA Define > Filter > Define User FIR > Oversample Ratio**

Page Down

Views the next page of listings in a table editor or catalog of files.

Page Down is located in table editor menus and in catalogs of files.

Page Up

Views the previous page of listings in a table editor or catalog of files.

Page Up is located in table editor menus and in catalogs of files.

PCCPCH

Inserts a primary common control physical channel (PCCPCH) into the downlink Edit Channel Setup table editor.

Softkey Location: **Mode > CDMA Formats > W-CDMA (3GPP 3.5 200103) > W-CDMA Define > Edit Channel Setup > Insert Row > PCCPCH**

PCCPCH + SCH

Selects a PCCPCH + SCH (PSCH + SSCH) downlink channel.

Softkey Location: **Mode > CDMA Formats > W-CDMA (3GPP 3.5 200103) > W-CDMA Select > PCCPCH + SCH**

PCCPCH + SCH + 1 DPCH

Selects a PCCPCH + SCH (PSCH + SSCH) + CPICH plus one DPCH downlink channel.

Softkey Location: **Mode > CDMA Formats > W-CDMA (3GPP 3.5 200103) > W-CDMA Select > PCCPCH + SCH + 1 DPCH**

PCCPCH + SCH + 3 DPCH

Selects a PCCPCH + SCH (PSCH + SSCH) + CPICH plus three DPCH downlink channels.

Softkey Location: **Mode > CDMA Formats > W-CDMA (3GPP 3.5 200103) > W-CDMA Select > PCCPCH + SCH + 3 DPCH**

PICH

Inserts a PICH channel into the downlink Edit Channel Setup table editor.

Softkey Location: **Mode > CDMA Formats > W-CDMA (3GPP 3.5 200103) > W-CDMA Define > Edit Channel Setup > Insert Row > PICH**

Plot CCDF

Displays a plot of the Complementary Cumulative Distribution Function for the selected waveform. The plot displays the probability that the instantaneous envelope power is x dB above the average power, where x is the number on the horizontal axis. This function is only available after a waveform has been generated.

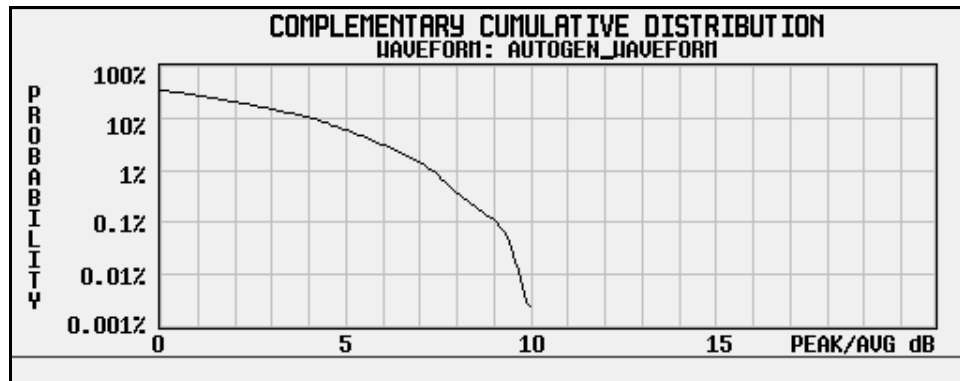

Softkey Location: **Mode > CDMA Formats > W-CDMA (3GPP 3.5 200103) > Waveform Statistics > Plot CCDF**

PN9

Press this softkey while an item is highlighted in the Data column of the table editor to enter a PN9 pseudorandom bit pattern as the channel data. PN9 appears in the Data Table Editor field. The bit pattern will be truncated or repeated as necessary to fill all of the data fields of the associated channel.

Softkey Location: **Mode > CDMA Formats > W-CDMA (3GPP 3.5 200103) > W-CDMA Define > Edit Channel Setup > (highlight a value in the data column) Edit Item > PN9**

Power

This softkey appears in the Multiple Channels menu, where you define a channel and then insert multiple entries of that channel into the downlink Edit Channel Setup table editor.

Press the **Power** softkey, then enter the value that you want for the power level of the channels that will be inserted.

After you set the channel parameters, and the number of times you want the channel duplicated, press **Done** to insert the information into the table editor.

Range: -40.00 through 0.00

Default Value: 0.00 dB

Softkey Location: **Mode > CDMA Formats > W-CDMA (3GPP 3.5 200103) > W-CDMA Define > Edit Channel Setup > Insert Row > Multiple Channels > Power**

Previous Scramble Code

Displays the code domain power graph of the previous channel when there is more than one combination of scramble code, scramble type, or scramble offset.

Softkey Location: **Mode > CDMA Formats > W-CDMA(3GPP 3.5 200103) > W-CDMA Define > Edit Channel Setup > Display Code Domain Power > Previous Scramble Code**

Primary Key

Selects the primary column by which the table will be sorted. The choices are the following:

| | |
|----------|----------------------|
| Downlink | Rate |
| | Spread Code |
| | Scramble Code |
| Uplink | Rate |
| | Spread Code |

NOTE

Primary and secondary key choices must be different.

Softkey Location: **Mode > CDMA Formats > W-CDMA (3GPP 3.5 200103) > W-CDMA Define > Edit Channel Setup > Sort Table > Primary Key**

PSCH

Inserts a PSCH channel into the downlink Edit Channel Setup table editor.

Softkey Location: **Mode > CDMA Formats > W-CDMA (3GPP 3.5 200103) > W-CDMA Define > Edit Channel Setup > Insert Row > PSCH**

Random

Press this softkey while an item is highlighted in the Data column of the table editor to enter random data as the channel data. **RANDOM** appears in the **Data Table Editor** field.

Softkey Location: **Mode > CDMA Formats > W-CDMA (3GPP 3.5 200103) > W-CDMA Define > Edit Channel Setup >** (highlight a value in the data column) **> Edit Item > Random**

Rate

Selects the data rate, **Rate ksp/s**, as a column by which the table will be sorted.

Softkey Location: **Mode > CDMA Formats > W-CDMA (3GPP 3.5 200103) > W-CDMA Define > Edit Channel Setup > Sort Table >**
Primary Key or Secondary Key > Rate

Reconstruction Filter

Displays a menu where you can select a reconstruction filter for the current link. You can choose a filter with a cutoff frequency of 250.0 kHz, 2.500 MHz, 8.000 MHz, or no filter (**Through**).

Default Value: 2.500 MHz

Softkey Location: **Mode > CDMA Formats > W-CDMA (3GPP 3.5 200103) > W-CDMA Define > Reconstruction Filter**

Rectangle

Selects a rectangle pre-modulation filter for the current link in either the **Select (filter)** menu or the **Load Default FIR** menu.

In the Select (Filter) Menu

Press the **Rectangle** softkey to select this FIR filter for use in your filter setup.

Softkey Location: **Mode > CDMA Formats > W-CDMA (3GPP 3.5 200103) > W-CDMA Define > Filter > Select > Rectangle**

In the Load Default FIR Menu

Pressing the **Rectangle** softkey followed by **Generate** loads the FIR table editor with the coefficient values for a rectangle filter.

The **Display Impulse Response** and **Display FFT** softkeys in this menu graphically display the filter as it is currently defined in the FIR table editor.

Softkey Location: **Mode > CDMA Formats > W-CDMA (3GPP 3.5 200103) > W-CDMA Define > Filter > Define User FIR > Load Default FIR > Rectangle**

Reference Frequency

Sets the reference frequency of the external clock. This key is available only when an external ARB reference is applied to the BASEBAND GEN REF IN connector.

Range: 250.0000 kHz through 20.0000000 MHz.

Default Value: 10.0000000 MHz

Softkey Location: **Mode > CDMA Formats > W-CDMA (3GPP 3.5 200103) > W-CDMA Define > Reference Freq**

Reset Table

Pressing **Reset Table** followed by **Confirm Table Reset** resets the uplink Edit Channel Setup Table editor to a single DPCCH channel.

Softkey Location: **Mode > CDMA Formats > W-CDMA (3GPP 3.5 200103) > Link Down Up > W-CDMA Define > Edit Channel Setup > Reset Table**

Restore Default Filter

Replaces the current FIR filter with the default filter (WCDMA) for the current link.

Softkey Location: **Mode > CDMA Formats > W-CDMA (3GPP 3.5 200103) > W-CDMA Define > Filter > Restore Default Filter**

Retrigger Mode Off On

Toggles the operating state of the retrigger mode for the current link. When retrigger mode is on, if a trigger occurs while a waveform is playing, the waveform retriggers at the end and plays one more time. If several triggers are received during a waveform, the waveform is replayed only once. When retrigger mode is off, if a trigger occurs while a waveform is playing, the retrigger is ignored.

Default Value: Off

Softkey Location: **Mode > CDMA Formats > W-CDMA (3GPP 3.5 200103) > Trigger > Trigger Setup > Retrigger Mode Off On**

Right Alternate

Sets the downlink channel scramble type to right alternate. Selecting **Right Alternate** adds 16384 to the scramble code.

Softkey Location: **Mode > CDMA Formats > W-CDMA (3GPP 3.5 200103) > W-CDMA Define > Edit Channel Setup > Modify All Scramble Codes > Scramble Type > Right Alternate**

Or: **Mode** > **CDMA Formats** > **W-CDMA (3GPP 3.5 200103)** > **W-CDMA Define** > **Edit Channel Setup** > **insert Rows** > **Multiple Channels** > **Scramble** > **Scramble Type** > **Right Alternate**

Root Nyquist

Selects the root Nyquist (root-raised cosine) pre-modulation filter for the current link in either the Select (filter) menu or the Load Default FIR menu.

In the Select (Filter) Menu

Pressing the **Root Nyquist** softkey selects this FIR filter and returns the Filter menu.

Softkey Location: **Mode** > **CDMA Formats** > **W-CDMA (3GPP 3.5 200103)** > **W-CDMA Define** > **Filter** > **Select** > **Root Nyquist**

In the Load Default FIR Menu

Pressing the **Root Nyquist** softkey followed by **Generate** loads the FIR table editor with the coefficient values for the root Nyquist filter. The filter alpha and number of filter symbols are defined with the softkeys in this menu. If you change either parameter after loading the filter coefficients, press the **Generate** softkey again to reload the FIR table.

The **Display Impulse Response** and **Display FFT** softkeys in this menu graphically display the filter as it is currently defined in the FIR table editor.

Softkey Location: **Mode** > **CDMA Formats** > **W-CDMA (3GPP 3.5 200103)** > **W-CDMA Define** > **Filter** > **Define User FIR** > **Load Default FIR** > **Root Nyquist**

Scale To 0dB

Scales all of the current channel powers so that the total power equals 0 dB while keeping the previous power ratios between the individual channels. Available in downlink only.

Softkey Location: **Mode** > **CDMA Formats** > **W-CDMA (3GPP 3.5 200103)** > **W-CDMA Define** > **Edit Channel Setup** > **Adjust Code Domain Power** > **Scale to 0dB**

SCCPCH

Inserts a secondary common control physical channel (SCCPCH) into the downlink Edit Channel Setup table editor.

Softkey Location: **Mode** > **CDMA Formats** > **W-CDMA (3GPP 3.5 200103)** > **W-CDMA Define** > **Edit Channel Setup** > **Insert Row** > **SCCPCH**

Scramble

This softkey appears in the Multiple Channels menu, where you can define a channel and then insert multiple entries of that channel into the downlink Edit Channel Setup table editor.

Press this softkey to access a menu where you can select the scramble code, scramble type, and scramble offset for those channels.

After you enter the desired values, press the **Done** softkey to terminate the entry.

Softkey Location: **Mode > CDMA Formats > W-CDMA (3GPP 3.5 200103) > W-CDMA Define > Edit Channel Setup > Insert Row > Multiple Channels > Scramble**

Scramble Code

The **Scramble Code** softkey is used for two different functions. One function enables you to define the scramble code. The other function selects the Scramble Code column in the table editor as a sorting item.

Defining a Scramble Code

This softkey appears in both the downlink Edit Channel Setup table editor and the uplink Edit Channel Setup table editor.

Downlink:

Defines the scramble code to be entered into the downlink Edit Channel Setup table editor. If the scramble offset is 0, this will generate a primary scramble code.

To change the scramble code, rotate the front-panel knob until the desired value is displayed, use the up and down arrow keys, or enter the value using the numeric keypad and press the **Enter** softkey.

Default Value: 0

Softkey Location: **Mode > CDMA Formats > W-CDMA (3GPP 3.5 200103) > W-CDMA Define > Edit Channel Setup > Modify All Scramble Codes > Scramble Code**

Or: **Mode > CDMA Formats > W-CDMA (3GPP 3.5 200103) > W-CDMA Define > Edit Channel Setup > Insert Row > Multiple Channels > Scramble > Scramble Code**

Uplink:

Displays a menu of scramble code values to be entered into the uplink Edit Channel Setup table editor.

To change the scramble code, choose a value from the menu, rotate the front-panel knob until the desired value is displayed, use the up down arrow keys, or enter the value using the numeric keypad and press the **Enter** softkey.

Default Value: 00000000000

Softkey Location: **Mode > CDMA Formats > W-CDMA (3GPP 3.5 200103) > Link Down Up > W-CDMA Define > Edit Channel Setup > Scramble Code**

Selecting a Sort Item

Selects the Scramble Code as a column by which the table will be sorted.

NOTE This softkey appears in the downlink table editor only.

Softkey Location: **Mode > CDMA Formats > W-CDMA (3GPP 3.5 200103) > W-CDMA Define > Edit Channel Setup > Sort Table > Primary Key (or Secondary Key) > Scramble Code**

Scramble Offset

Sets the scramble offset to be entered into the downlink Edit Channel Setup table editor. This is a value from 0 to 15 that is added to the primary code multiplied by 16. The primary code is entered under the scramble code softkey.

To change the scramble offset, rotate the front-panel knob until the desired value is displayed, use the up and down arrow keys, or enter the value using the numeric keypad and press the **Enter** softkey.

Default Value: 0

Softkey Location: **Mode > CDMA Formats > W-CDMA (3GPP 3.5 200103) > W-CDMA Define > Edit Channel Setup > Modify All Scramble Codes > Scramble Offset**

Or: **Mode > CDMA Formats > W-CDMA (3GPP 3.5 200103) > W-CDMA Define > Edit Channel Setup > Insert Row > Multiple Channels > Scramble > Scramble Offset**

Scramble Type

Accesses a menu where you can select Standard, Right Alternate, or Left Alternate as the scramble type in the downlink Edit Channel Setup table editor.

Default Value: Standard

Softkey Location: **Mode > CDMA Formats > W-CDMA (3GPP 3.5 200103) > W-CDMA Define > Edit Channel Setup > Modify All Scramble Codes > Scramble Type**

Or: **Mode > CDMA Formats > W-CDMA (3GPP 3.5 200103) > W-CDMA Define > Edit Channel Setup > Insert Row > Multiple Channels > Scramble > Scramble Type**

Second DPDCH I Q

Allows you to set the second DPDCH channel to I or Q.

Softkey Location: **Mode > CDMA Formats > W-CDMA (3GPP 3.5 200103) > Link Down Up > W-CDMA Define > Edit Channel Setup > Second DPDCH I Q**

Secondary Key

Selects the secondary column by which the table will be sorted. The choices are the following:

| | |
|----------|---|
| Downlink | Rate Spread Code Scramble Code |
| Uplink | Rate Spread Code |

NOTE

Primary and secondary key choices must be different.

Softkey Location: **Mode > CDMA Formats > W-CDMA (3GPP 3.5 200103) > W-CDMA Define > Edit Channel Setup > Sort Table > Secondary Key**

Select

Accesses a menu where you can select the pre-modulation filter type for the current link.

You can choose from:

Pre-defined filters, such as root Nyquist, Nyquist, Gaussian, several IS-95/IS-2000 baseband filters, User FIR, Rectangle, APCO 25 C4FM, and UN3/4 GSM Gaussian. When you access this menu through the W-CDMA menus, a filter optimized for W-CDMA is also available.

The standard IS-95 filter is available as well as a modified version of this filter that meets the IS-95 error function for improved adjacent channel performance. These two filters are also provided with an equalizer for phase compensation required by the base station.

A catalog of files is stored in the signal generator's memory.

Default Value: WCDMA

Softkey Location: **Mode > CDMA Formats > W-CDMA (3GPP 3.5 200103) > W-CDMA Define > Filter > Select**

Single

Sets the trigger type to single. After receiving a trigger, the waveform is output once.

Softkey Location: **Mode > CDMA Formats > W-CDMA (3GPP 3.5 200103) > Trigger > Single**

Select File

Selects a stored file.

Select File is located in catalogs of files.

Sort

Sorts the W-CDMA channel table editor by the selected primary and secondary keys.

Softkey Location: **Mode > CDMA Formats > W-CDMA (3GPP 3.5 200103) > W-CDMA Define > Edit Channel Setup > Sort Table > Sort**

Sort Table

Accesses a menu where you can sort the table editor files by selecting primary and secondary keys. The keys are columns of the table.

Sorting of the uplink channel is done by **Spread Code** and/or **Rate**. The downlink channel can be sorted by **Spread Code**, **Rate** and/or **Scramble Code**.

Softkey Location: **Mode > CDMA Formats > W-CDMA (3GPP 3.5 200103) > W-CDMA Define > Edit Channel Setup > Sort Table**

Spread Code

Selects the **Spread Code** as a column by which the table will be sorted.

Softkey Location: **Mode > CDMA Formats > W-CDMA (3GPP 3.5 200103) > W-CDMA Define > Edit Channel Setup > Sort Table > Primary Key**
or **Secondary Key > Spread Code**

SSCH

Inserts a SSCH channel into the downlink Edit Channel Setup table editor.

Softkey Location: **Mode > CDMA Formats > W-CDMA (3GPP 3.5 200103) > W-CDMA Define > Edit Channel Setup > Insert Row > SSCH**

Standard

Sets the downlink channel scramble type to standard.

Softkey Location: **Mode > CDMA Formats > W-CDMA (3GPP 3.5 200103) > W-CDMA Define > Edit Channel Setup > Modify All Scramble Codes > Scramble Type > Standard**

Or: **Mode > CDMA Formats > W-CDMA (3GPP 3.5 200103) > W-CDMA Define > Edit Channel Setup > insert Rows > Multiple Channels > Scramble > Scramble Type > Standard**

Store Custom Multicarrier

Accesses a menu where you can store the contents of the multicarrier table editor into a file.

This softkey stores the following information for each carrier:

- type of carrier
- frequency offset
- power level

Softkey Location: **Mode > CDMA Formats > W-CDMA (3GPP 3.5 200103) > Multicarrier Off On > Multicarrier Define > Store Custom Multicarrier**

NOTE

To recall a file, press **Mode > CDMA Formats > W-CDMA (3GPP 3.5 200103) > Multicarrier Off On > W-CDMA Select > Custom W-CDMA Multicarrier**, and select the desired file.

Store Custom W-CDMA State

Accesses a menu where you can store the current custom W-CDMA state into a file that can be recalled for later use (as described under the softkey [Custom W-CDMA State](#)).

Along with the contents of the W-CDMA channel table editor, the following information is also stored:

- FIR filter
- FIR filter file name
- FIR filter alpha
- FIR filter BbT
- FIR filter channel (EVM or ACP)
- I/Q Mapping
- Link
- chip rate

- ARB reconstruction filter
- ARB reference clock source (internal or external)
- ARB reference clock frequency
- Clipping Level
- Downlink TFCI state
- Uplink TFCI state
- Uplink DPDCH (second DPDCH I or Q)
- Uplink Scramble Code

Softkey Location: **Mode > CDMA Formats > W-CDMA (3GPP 3.5 200103) > W-CDMA Define > Store Custom W-CDMA State**

Store To File

Displays a menu that enables you to name the file to be stored in the catalog of files.

Store To File is located in catalogs of files.

Symbol Rate

This softkey appears in both the downlink Edit Channel Setup table editor and the uplink Edit Channel Setup table editor.

Downlink:

This softkey appears in the Multiple Channels menu where you define a channel and then insert multiple entries of that channel into the downlink Edit Channel Setup table editor.

Press the **Symbol Rate** softkey, then select the symbol rate that you want for the channel definition. Press the **Enter** softkey to terminate the entry.

After you have set the channel parameters and the number of times you want the channel duplicated, press **Done** to insert the information into the table editor.

Default Value: 30 kbps

Softkey Location: **Mode > CDMA Formats > W-CDMA (3GPP 3.5 200103) > W-CDMA Define > Edit Channel Setup > Insert Row > Multiple Channels > Symbol Rate**

Uplink:

This softkey appears in the Insert DPDCH menu where you can select a preset value for the symbol rate.

Press the **Symbol Rate** softkey, then select the symbol rate that you want for the channel definition.

After you have set the channel parameters and the number of times you want the channel duplicated, press **Done** to insert the information into the table editor.

Default Value: 60 ksps

Softkey Location: **Mode > CDMA Formats > W-CDMA (3GPP 3.5 200103) > Link Down Up > W-CDMA Define > Edit Channel Setup > Insert DPDCH > Symbol Rate**

Test Models

Press this softkey to display a menu of the Test Models for the W-CDMA downlink channel setup.

Softkey Location: **Mode > CDMA Formats > W-CDMA (3GPP 3.5 200103) > W-CDMA Select > Test Models**

Test Model 1 W/ 16 DPCH

Selects Test Model 1 with 16 DPCH channels for the W-CDMA downlink channel setup.

Softkey Location: **Mode > CDMA Formats > W-CDMA (3GPP 3.5 200103) > W-CDMA Select > Test Models > Test Model 1 W/ 16 DPCH**

Or: **Mode > CDMA Formats > W-CDMA (3GPP 3.5 200103) > Multicarrier On Off > Multicarrier Define > Edit Item (or Insert Row) > Test Models > Test Model 1 W/ 16 DPCH**

Test Model 1 W/ 32 DPCH

Selects Test Model 1 with 32 DPCH channels for the W-CDMA downlink channel setup.

Softkey Location: **Mode > CDMA Formats > W-CDMA (3GPP 3.5 200103) > W-CDMA Select > Test Models > Test Model 1 W/ 32 DPCH**

Or: **Mode > CDMA Formats > W-CDMA (3GPP 3.5 200103) > Multicarrier On Off > Multicarrier Define > Edit Item (or Insert Row) > Test Models > Test Model 1 W/ 32 DPCH**

Test Model 1 W/ 64 DPCH

Selects Test Model 1 with 64 DPCH channels for the W-CDMA downlink channel setup.

Softkey Location: **Mode > CDMA Formats > W-CDMA (3GPP 3.5 200103) > W-CDMA Select > Test Models > Test Model 1 W/ 64 DPCH**

Or: **Mode > CDMA Formats > W-CDMA (3GPP 3.5 200103) > Multicarrier On Off > Multicarrier Define > Edit Item (or Insert Row) > Test Models > Test Model 1 W/ 64 DPCH**

Test Model 2

Selects Test Model 2 for the W-CDMA downlink channel setup.

Softkey Location: **Mode > CDMA Formats > W-CDMA (3GPP 3.5 200103) > W-CDMA Select > Test Models > Test Model 2**

Or: **Mode > CDMA Formats > W-CDMA (3GPP 3.5 200103) > Multicarrier On Off > Multicarrier Define > Edit Item (or Insert Row) > Test Models > Test Model 2**

Test Model 3 W/ 16 DPCH

Selects Test Model 3 with 16 DPCH channels for the W-CDMA downlink channel setup.

Softkey Location: **Mode > CDMA Formats > W-CDMA (3GPP 3.5 200103) > W-CDMA Select > Test Models > Test Model 3 W/ 16 DPCH**

Or: **Mode > CDMA Formats > W-CDMA (3GPP 3.5 200103) > Multicarrier On Off > Multicarrier Define > Edit Item (or Insert Row) > Test Models > Test Model 3 W/ 16 DPCH**

Test Model 3 W/ 32 DPCH

Selects Test Model 3 with 32 DPCH channels for the W-CDMA downlink channel setup.

Softkey Location: **Mode > CDMA Formats > W-CDMA (3GPP 3.5 200103) > W-CDMA Select > Test Models > Test Model 3 W/ 32 DPCH**

Or: **Mode > CDMA Formats > W-CDMA (3GPP 3.5 200103) > Multicarrier On Off > Multicarrier Define > Edit Item (or Insert Row) > Test Models > Test Model 3 W/ 32 DPCH**

Test Model 4

Selects Test Model 4 for the W-CDMA downlink channel setup.

Softkey Location: **Mode > CDMA Formats > W-CDMA (3GPP 3.5 200103) > W-CDMA Select > Test Models > Test Model 4**

Or: **Mode > CDMA Formats > W-CDMA (3GPP 3.5 200103) > Multicarrier On Off > Multicarrier Define > Edit Item (or Insert Row) > Test Models > Test Model 4**

TFCI Field Off On

Turns the TFCI field on or off for all the channels in the current table editor.

Default Value: On

Softkey Location: **Mode > CDMA Formats > W-CDMA (3GPP 3.5 200103) > W-CDMA Define > Edit Channel Setup > TFCI Field Off On**

Through

Bypasses all reconstruction filtering for the current link. This is useful for using external reconstruction filters at frequencies different than those supplied internally.

Softkey Location: **Mode > CDMA Formats > W-CDMA (3GPP 3.5 200103) > W-CDMA Define > Reconstruction Filter > Through**

Trigger

Displays the trigger menu, where you can select types of triggering. The menu also contains a **Trigger Setup** key that enables you to adjust the trigger source, the retrigger mode, and the gate active polarity.

Default Value: Continuous

Softkey Location: **Mode > CDMA Formats > W-CDMA (3GPP 3.5 200103) > Trigger**

Trigger Key

Sets the trigger source to the signal generator's front-panel **Trigger** hardkey. When the trigger source is set to **Trigger Key**, the signal generator will trigger an event when the **Trigger** hardkey is pressed.

Softkey Location: **Mode > CDMA Formats > W-CDMA (3GPP 3.5 200103) > Trigger > Trigger Setup > Trigger Source > Trigger Key**

Trigger Setup

Displays a menu where you can select the trigger source, the retrigger mode, and the gate active polarity.

Softkey Location: **Mode > CDMA Formats > W-CDMA (3GPP 3.5 200103) > Trigger > Trigger Setup**

Trigger Source

Displays the trigger source menu where you can adjust the trigger source between the front panel **Trigger** key, a trigger command sent over the GPIB bus, or an external trigger applied to the PATTERN TRIG IN connector.

Default Value: Ext

Softkey Location: **Mode > CDMA Formats > W-CDMA (3GPP 3.5 200103) > Trigger > Trigger Source**

Type

Displays a menu where you can select the type of channel that you want to set up and insert multiple times into the downlink Edit Channel Setup table editor. After you have set the channel parameters, and the number of times you want the channel duplicated, press **Done** to insert the information into the table editor.

Default Value: DPCH

Softkey Location: **Mode > CDMA Formats > W-CDMA (3GPP 3.5 200103) > W-CDMA Define > Edit Channel Setup > Insert Row > Multiple Channels > Type**

UN3/4 GSM Gaussian

This key selects a UN3/4 delay compatible, GSM, Gaussian filter with a 0.300 fixed BbT.

Softkey Location: **Mode > CDMA Formats > W-CDMA (3GPP 3.5 200103) > W-CDMA Define > Filter > Select > UN3/4 GSM Gaussian**

User FIR

Displays the catalog of FIR filter files stored in the signal generator's memory. You can select a custom filter from this catalog for your pre-modulation filter for the current link. Scroll through the listed files and when your selection is highlighted, press the **Select File** softkey. The **User FIR** is shown in the **Filter** field of the display, and the file name is shown in the second line of the **Select** softkey.

Softkey Location: **Mode > CDMA Formats > W-CDMA (3GPP 3.5 200103) > W-CDMA Define > Filter > Select > User FIR**

View Next Page

Displays more of the code domain power graph than can be shown on the display. To return to the start, press **View Next Page** until you cycle through the entire code domain space and return to the display of code domain 0—127.

Softkey Location: **Mode > CDMA Formats > W-CDMA (3GPP 3.5 200103) > W-CDMA Define > Edit Channel Setup > Display Code Domain Power > View Next Page**

Waveform Statistics

This grayed-out softkey is active only when a waveform is generated. When this softkey is active statistics are available for the selected waveform.

Softkey Location: **Mode > CDMA Formats > W-CDMA (3GPP 3.5 200103) > Waveform Statistics**

WCDMA

Selects the WCDMA pre-modulation filter in the Select (filter) menu. Pressing the **WCDMA** softkey selects this FIR filter and returns the Filter menu.

Softkey Location: **Mode > CDMA Formats > W-CDMA (3GPP 3.5 200103) > W-CDMA Define > Filter > Select > WCDMA**

W-CDMA (3GPP 3.5 200103)

Opens a menu of softkeys where you can generate data patterns that are formatted into a structure defined by the W-CDMA (3GPP 3.5 200103) standard.

This softkey is available *only* if both Option UND and Option 100 are installed.

Softkey Location: **Mode > CDMA Formats > W-CDMA (3GPP 3.5 200103)**

W-CDMA Define

Displays the W-CDMA Define menu for the current link, where you can define a W-CDMA signal. With the **Multicarrier Off On** softkey set to **On**, this softkey is replaced with the **Multicarrier Define** softkey (see [“Multicarrier Define”](#) on page 3-25).

Softkey Location: **Mode > CDMA Formats > W-CDMA (3GPP 3.5 200103) > W-CDMA Define**

W-CDMA Off On

Enables W-CDMA baseband signal generation. Turning W-CDMA on sets up the internal hardware to generate the currently selected W-CDMA signal. The W-CDMA and I/Q annunciators appear on the display. The W-CDMA signal modulates the RF carrier *only* after you have set the front panel **Mod On/Off** key to **On**.

Default Value: Off

Softkey Location: **Mode > CDMA Formats > W-CDMA (3GPP 3.5 200103) > W-CDMA Off On**

W-CDMA Select

The function of this softkey changes, depending on whether multicarrier mode is off (default) or on. (Refer to “[Multicarrier Off On](#)” on page 3-26.)

Multicarrier Off

Displays the W-CDMA Select menu for the current link, where you can select a predefined channel setup or a stored custom state.

Default Value: 1 DPCH

Softkey Location: **Mode > CDMA Formats > W-CDMA (3GPP 3.5 200103) > W-CDMA Select**

Multicarrier On

Displays the multicarrier W-CDMA Select menu, where you can select a predefined multicarrier setup or a stored custom multicarrier setup.

NOTE

The **Multicarrier Off ON** softkey and related functions are accessed only when using the W-CDMA downlink setup.

Default Value: 2 Carriers

Softkey Location: **Mode > CDMA Formats > W-CDMA (3GPP 3.5 200103) > W-CDMA Select**

Window

Pressing this softkey accesses a menu for applying a windowing function to the selected filter. The default is to use no windowing which optimizes the passband response (EVM). Several windowing selections are provided in this menu which can be applied to smooth the filter's transition to zero. Windowing improves adjacent channel power performance (ACP) but simultaneously degrades EVM

Default Value: None

Softkey Location: **Mode > CDMA Formats > W-CDMA (3GPP 3.5 200103) > W-CDMA Define > Filter > Define User FIR > Load Default FIR > Root Nyquist (or Nyquist or Gaussian or Rectangle) > Window**

4 Operation

This chapter contains detailed information that will help you understand the operation of your Option 100 signal generator's W-CDMA (3GPP 3.5 2001-03) personality.

W-CDMA Frame Structures

This section contains graphical representations of W-CDMA frame structures, with associated tables, for both downlink and uplink channels.

Downlink PICH Frame Structure

Figure 4-1 PICH Frame Structure

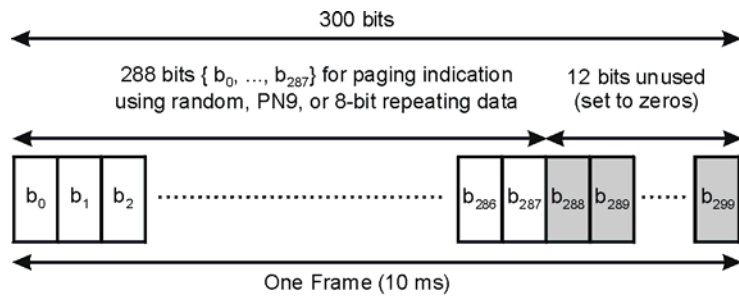

Symbol rate = 15 ksps

pk767t

Downlink PCCPCH + SCH Frame Structure

Figure 4-2 PCCPCH + SCH Frame Structure

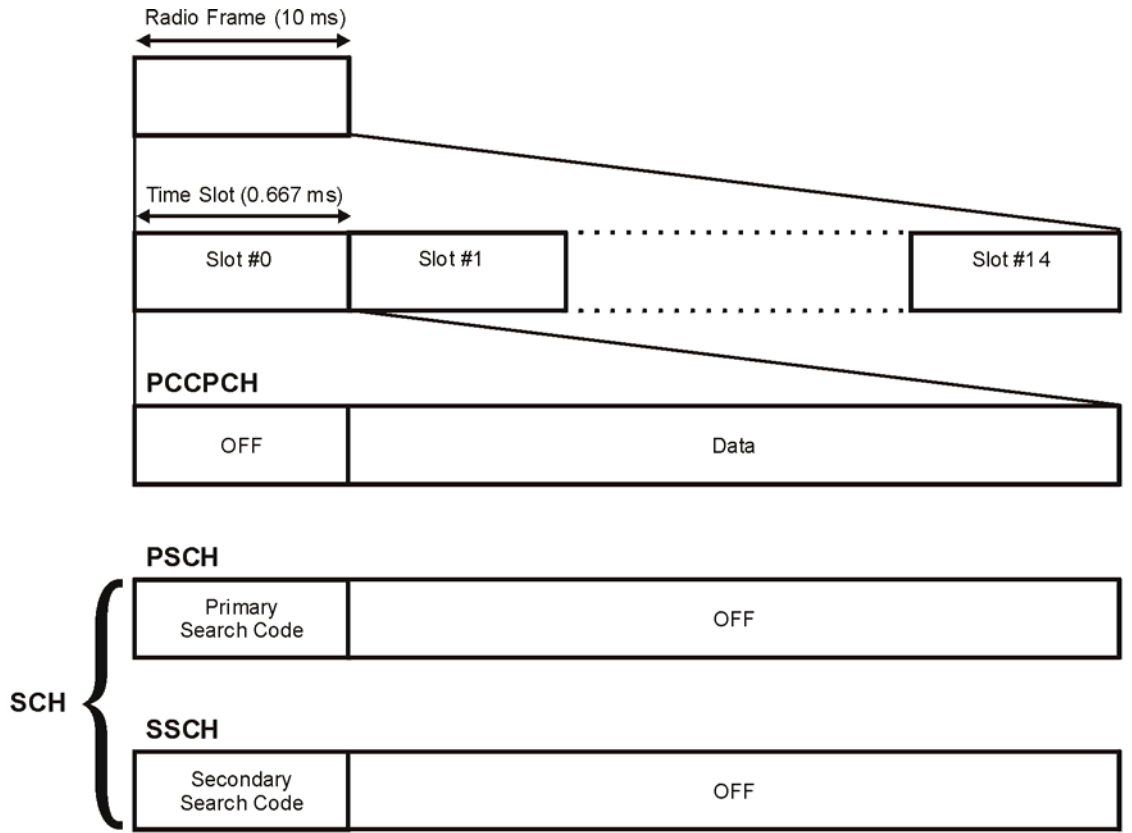

pk760b

Table 4-1 Lengths of PCCPCH + SCH Fields

| Parameter | Symbols Per Slot |
|-------------|------------------|
| N_{data} | 9 |
| N_{SCH}^a | 1 |

a. SCH is comprised of PSCH and SSCH

Downlink DPDCH/DPCCH Frame Structure

Figure 4-3 DPDCH/DPCCH Frame Structure

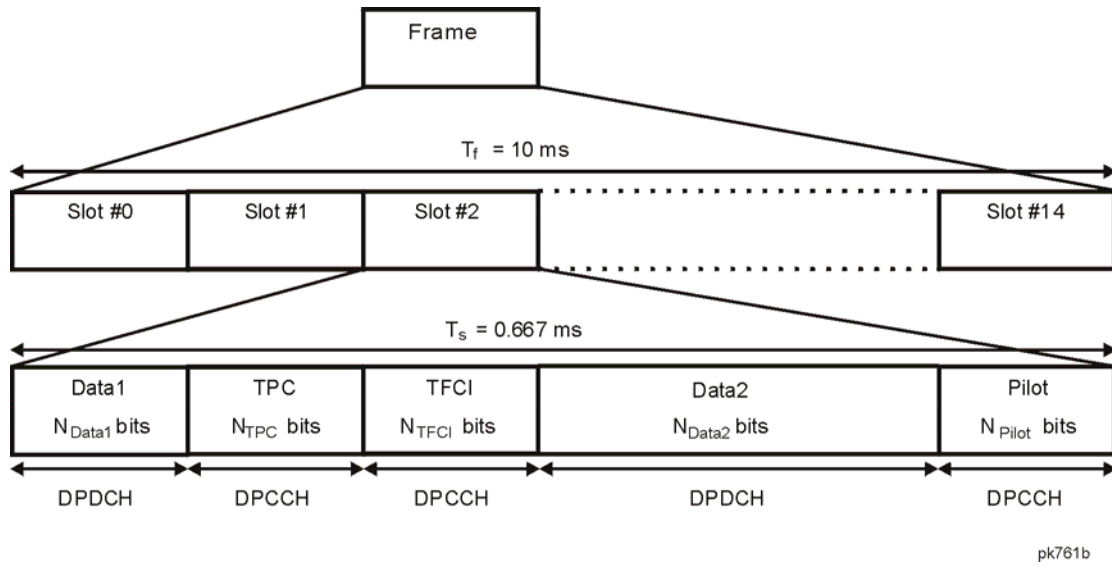

Table 4-2 DPDCH and DPCCH Fields

| Channel Bit Rate (kbps) | Channel Symbol Rate (ksps) | Spread Factor | Bits/Frame | | | Bits/Slot | DPDCH Bits/Slot | | DPCCH Bits/Slot | | |
|-------------------------|----------------------------|---------------|------------|-------|-------|-----------|--------------------|--------------------|-------------------|------------------|--------------------|
| | | | DPDCH | DPCCH | TOTAL | | N _{data1} | N _{data2} | N _{TFCI} | N _{TPC} | N _{pilot} |
| 15 | 7.5 | 512 | 60 | 90 | 150 | 10 | 0 | 4 | 0 | 2 | 4 |
| 15 | 7.5 | 512 | 30 | 120 | 150 | 10 | 0 | 2 | 2 | 2 | 4 |
| 30 | 15 | 256 | 240 | 60 | 300 | 20 | 2 | 14 | 0 | 2 | 2 ^a |
| 30 | 15 | 256 | 210 | 90 | 300 | 20 | 2 | 12 | 2 | 2 | 2 ^a |
| 30 | 15 | 256 | 210 | 90 | 300 | 20 | 2 | 12 | 0 | 2 | 4 ^a |
| 30 | 15 | 256 | 180 | 120 | 300 | 20 | 2 | 10 | 2 | 2 | 4 ^a |
| 30 | 15 | 256 | 150 | 150 | 300 | 20 | 2 | 8 | 0 | 2 | 8 ^a |
| 30 | 15 | 256 | 120 | 180 | 300 | 20 | 2 | 6 | 2 | 2 | 8 ^a |
| 60 | 30 | 128 | 510 | 90 | 600 | 40 | 6 | 28 | 0 | 2 | 4 ^a |
| 60 | 30 | 128 | 480 | 120 | 600 | 40 | 6 | 26 | 2 | 2 | 4 ^a |
| 60 | 30 | 128 | 450 | 150 | 600 | 40 | 6 | 24 | 0 | 2 | 8 ^a |
| 60 | 30 | 128 | 420 | 180 | 600 | 40 | 6 | 22 | 2 | 2 | 8 ^a |
| 120 | 60 | 64 | 900 | 300 | 1200 | 80 | 12 | 48 | g ^b | 4 | 8 |
| 240 | 120 | 32 | 2100 | 300 | 2400 | 160 | 28 | 112 | g ^b | 4 | 8 |
| 480 | 240 | 16 | 4320 | 480 | 4800 | 320 | 56 | 232 | g ^b | 8 | 16 |
| 960 | 480 | 8 | 9120 | 480 | 9600 | 640 | 120 | 488 | g ^b | 8 | 16 |
| 1920 | 960 | 4 | 18720 | 480 | 19200 | 1280 | 248 | 1000 | g ^b | 8 | 16 |

- a. The number of pilot bits can vary with channel symbol rates of 15 and 30 ksps.
b. If TFCI bits are not used, then DTX (discontinuous transmission) is used in the TFCI field.

Uplink DPDCH/DPCCH Frame Structure

Figure 4-4 DPDCH/DPCCH Frame Structure

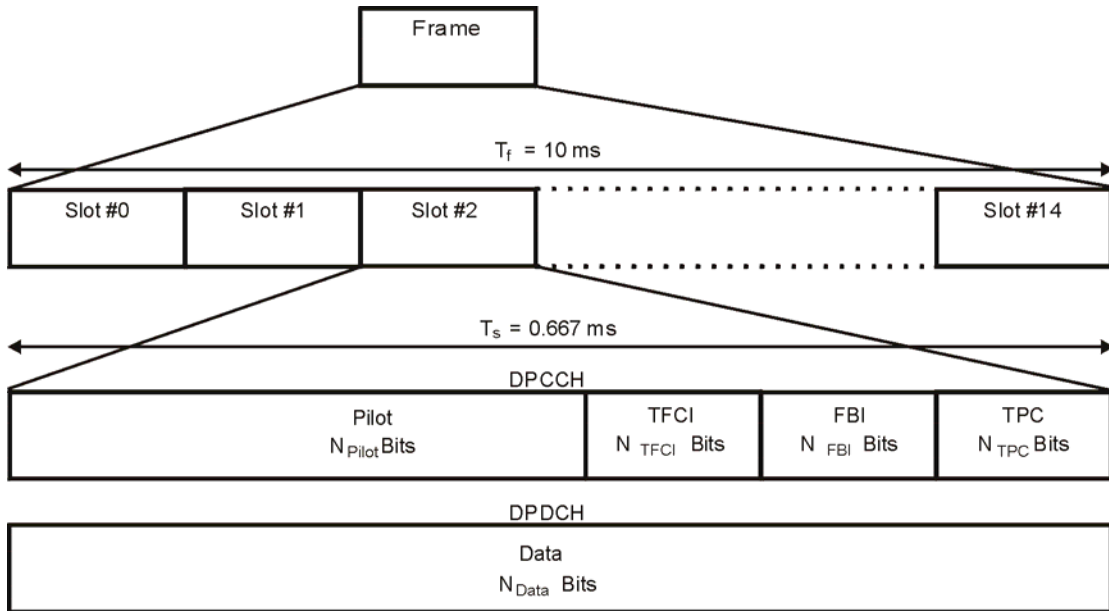

pk762t

Table 4-3 DPDCH Fields

| Channel Bit Rate (kbps) | Channel Symbol Rate (ksps) | Spread Factor | Bits/Frame | Bits/Slot | N_{data} |
|-------------------------|----------------------------|---------------|------------|-----------|-------------------|
| 15 | 15 | 256 | 150 | 10 | 10 |
| 30 | 30 | 128 | 300 | 20 | 20 |
| 60 | 60 | 64 | 600 | 40 | 40 |
| 120 | 120 | 32 | 1200 | 80 | 80 |
| 240 | 240 | 16 | 2400 | 160 | 160 |
| 480 | 480 | 8 | 4800 | 320 | 320 |
| 960 | 960 | 4 | 9600 | 640 | 640 |

Table 4-4 DPCCH Fields

| Channel Bit Rate (kbps) | Channel Symbol Rate (ksps) | Spread Factor | Bits/Frame | Bits/Slot | N_{pilot} | N_{TFCI} | N_{FBI} | N_{TPC} |
|-------------------------|----------------------------|---------------|------------|-----------|--------------------|-------------------|------------------|------------------|
| 15 | 15 | 256 | 150 | 10 | 6 | 2 | 0 | 2 |
| 15 | 15 | 256 | 150 | 10 | 8 | 0 | 0 | 2 |
| 15 | 15 | 256 | 150 | 10 | 5 | 2 | 1 | 2 |
| 15 | 15 | 256 | 150 | 10 | 7 | 0 | 1 | 2 |
| 15 | 15 | 256 | 150 | 10 | 6 | 0 | 2 | 2 |
| 15 | 15 | 256 | 150 | 10 | 5 | 2 | 2 | 1 |

Understanding TPC Values

TPC values determine how the transmit power of the receiving base or mobile station will vary. In the channel table editor, TPC values are represented in hexadecimal format to simplify entries and modifications. Figure 4-5 shows the channel table editor with the TPC value, 7F80, highlighted.

Figure 4-5 Highlighted TPC Value

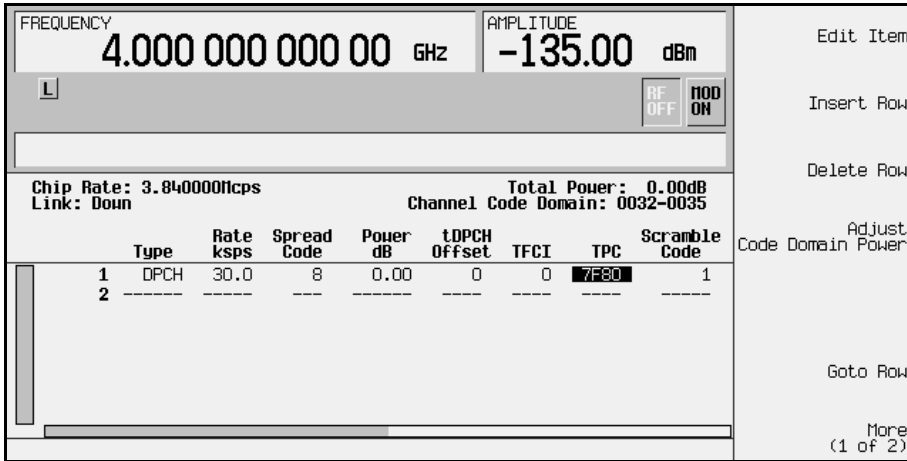

Hexadecimal TPC values are converted to their binary equivalent. In this example, the value 7F80 becomes 111 1111 1000 0000. Notice that there are 15 digits in the binary TPC value. Because one frame contains 15 timeslots, one binary digit is assigned to each timeslot (see Figure 4-6). The assigned bit is then repeated enough times to fill the TPC bit field (See the N_{TPC} column of Table 4-2 on page 4-4). Since the example in Figure 4-6 uses two TPC bits per timeslot, the values are either 11 or 00.

The TPC bits that are ones direct the receiving base or mobile station to increase its transmit power by an amount specified by the W-CDMA standard. Likewise, TPC bits that are zeros cause the power to decrease by the same amount. In this example, the transmit power is increasing over timeslots 0 through 7 and decreasing over timeslots 8 through 14.

Figure 4-6 TPC Bits per Timeslot

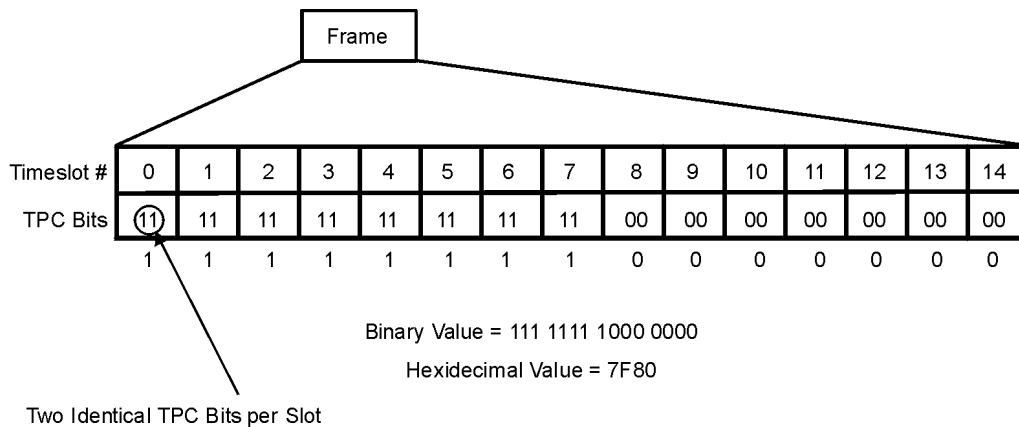

pk758b

Understanding TFCI, TPC, and Pilot Power Offsets

TFCI, TPC, and Pilot power offsets (PO), which are applied to downlink control channels (DPCCH), are relative to the transmit power for data channels (DPDCH). Usually, these offsets are set to a positive value (refer to [Figure 4-7](#)). The intent is to transmit control symbols at a higher level than data symbols to maintain the link between mobile and base. Because only the DPCCH transmit power is offset, the total transmit power is minimized and less noise is generated in the system.

Figure 4-7 TFCI, TPC, and Pilot Power

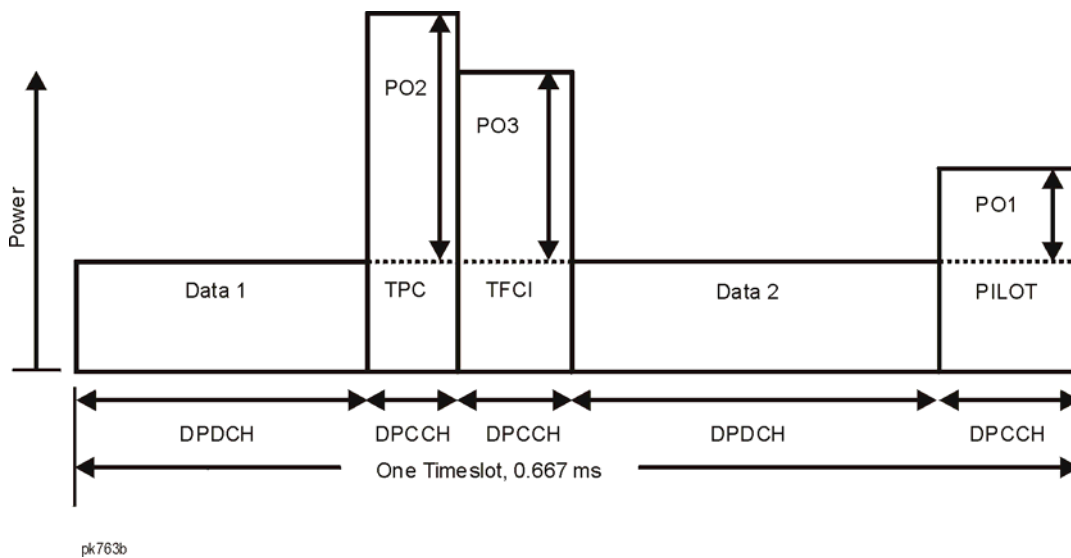

The display in [Figure 4-8](#) shows that the channel in row 6 of the table editor has the data transmit power (Power dB) set to -6.02 dB with the following offsets: TFCI Power set to 2.00 dB, TPC Power set to 3.00 dB, and Pilot Power set to 1.00 dB. Because of these offsets, the control symbols corresponding to TFCI, TPC, and Pilot will transmit at -4.02 dB, -3.02 dB, and -5.02 dB respectively.

Figure 4-8 Table Editor Showing TFICI, TPC, and Pilot Power Offsets

| FREQUENCY | | | | AMPLITUDE | | | | | | | |
|---------------------------------------|------------|-------------|----------|---|--------------|----------------|------------|------|---------------|--------|-----|
| 4.000 000 000 00 GHz | | | | 000 000 000 00 GHz -135.00 dBm | | | | | | | |
| Chip Rate: 3.840000Mcps Link: Down | | | | Chip Rate: 3.840000Mcps Channel Code Domain: 0040-0043 | | | | | | | |
| Type | Rate ksp/s | Spread Code | Power dB | TFICI Power dB | TPC Power dB | Pilot Power dB | Pilot Bits | Data | Scramble Type | Offset | |
| 1 | PCCPCH | 15.0 | 1 | -9.02 | N/A | N/A | N/A | N/A | RANDOM | STD | 0 |
| 2 | PSCH | 15.0 | N/A | -12.02 | N/A | N/A | N/A | N/A | N/A | N/A | N/A |
| 3 | SSCH | 15.0 | N/A | -12.02 | N/A | N/A | N/A | N/A | N/A | N/A | 0 |
| 4 | CPICH | 15.0 | 0 | -9.02 | N/A | N/A | N/A | N/A | 00000000 | STD | 0 |
| 5 | DPCH | 30.0 | 8 | -6.02 | 0.00 | 0.00 | 0.00 | 4 | RANDOM | STD | 0 |
| 6 | DPCH | 30.0 | 9 | -6.02 | 2.00 | 3.00 | 1.00 | 4 | RANDOM | STD | 0 |
| 7 | DPCH | 30.0 | 10 | -6.02 | 0.00 | 0.00 | 0.00 | 4 | RANDOM | STD | 0 |
| 8 | | | | | | | | | | | |

pk759b

Understanding Baseband Clipping

In a W-CDMA waveform, high power peaks can cause intermodulation distortion, which generates spectral regrowth (a condition that interferes with signals in adjacent frequency bands). The clipping function allows you to reduce high power peaks.

How Power Peaks Develop

To understand how clipping reduces high power peaks in a W-CDMA signal, it is important to know how the peaks develop as the signal is constructed.

A W-CDMA waveform is composed of an I waveform and a Q waveform. Often, these waveforms are the summation of multiple channels (refer to [Figure 4-9](#)). Whenever most or all of the individual channel waveforms simultaneously contain a bit in the same state (high or low), an unusually high power peak (negative or positive) occurs in the summed waveform. This does *not* happen frequently because the high and low states of the bits on these channel waveforms are random, which causes a cancelling effect.

Figure 4-9 Multiple Channel Summing

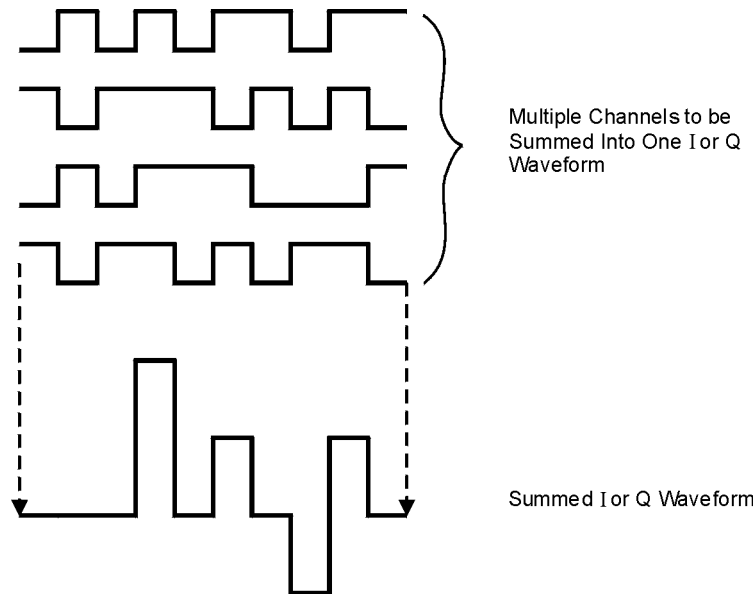

pk722b

The I and Q waveforms combine in the I/Q modulator to create an RF waveform. The magnitude of the RF envelope is determined by the equation $\sqrt{I^2+Q^2}$, where the squaring of I and Q always results in a positive value. Notice how simultaneous positive and negative peaks in the I and Q waveforms do not cancel each other, but combine to create an even greater peak (refer to [Figure 4-10](#)).

Figure 4-10 Combining the I and Q Waveforms

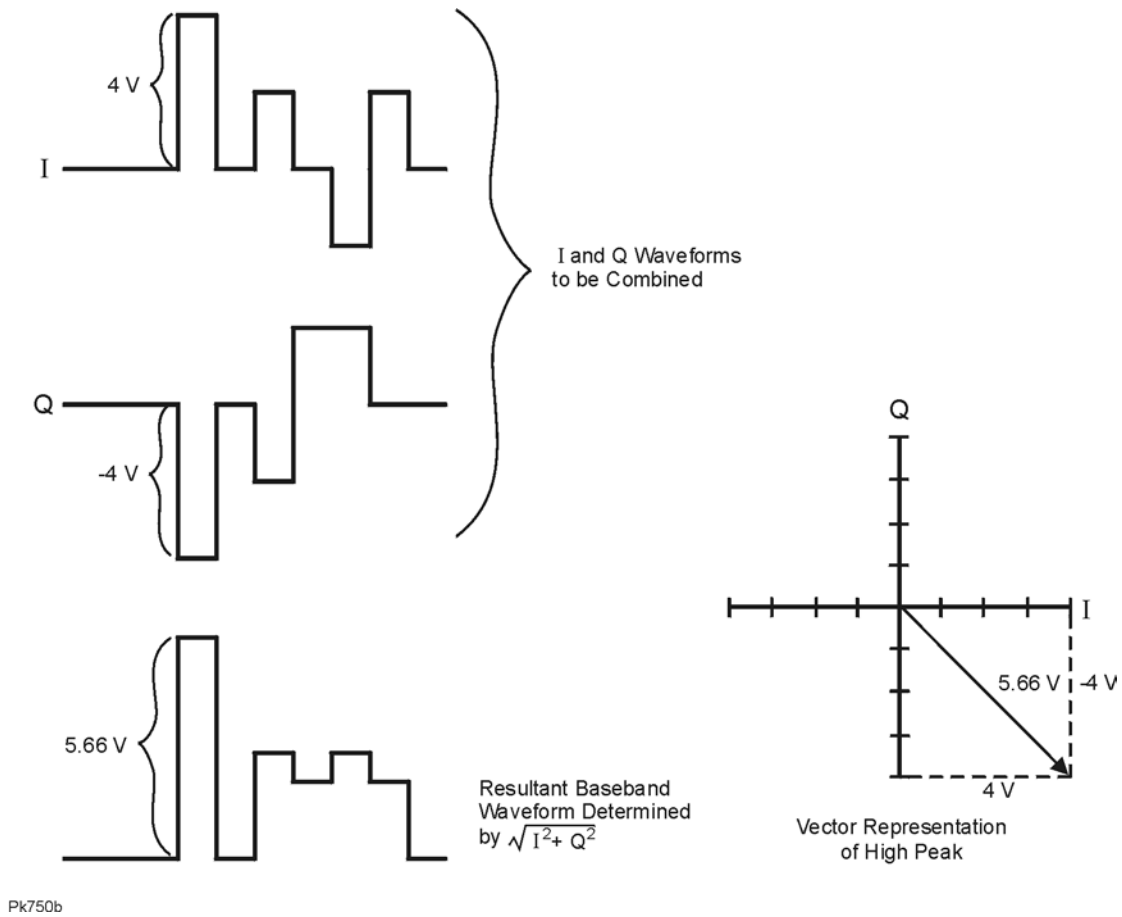

How Peaks Cause Spectral Regrowth

Because of the relative infrequency of high power peaks, a waveform will have a high peak-to-average power ratio (refer to [Figure 4-11](#)). Because a transmitter's power amplifier gain is set to provide a specific average power, high peaks can cause the power amplifier to move toward saturation. This causes intermodulation distortion, which generates spectral regrowth.

Figure 4-11 Peak-to-Average Power in the W-CDMA Waveform

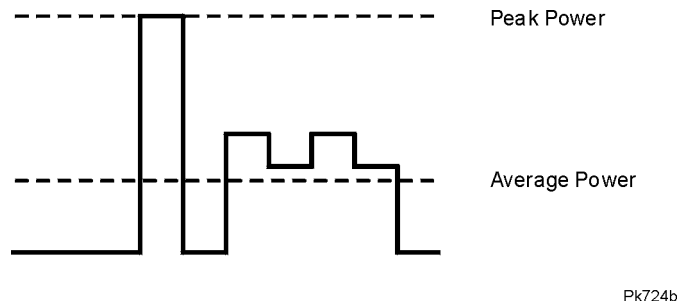

Spectral regrowth is a range of frequencies that develops on each side of the carrier (similar to sidebands) and extends into the adjacent frequency bands (refer to [Figure 4-12](#)). Consequently, spectral regrowth interferes with communication in the adjacent bands. Clipping can provide a solution to this problem.

Figure 4-12 Spectral Regrowth Interfering with Adjacent Band

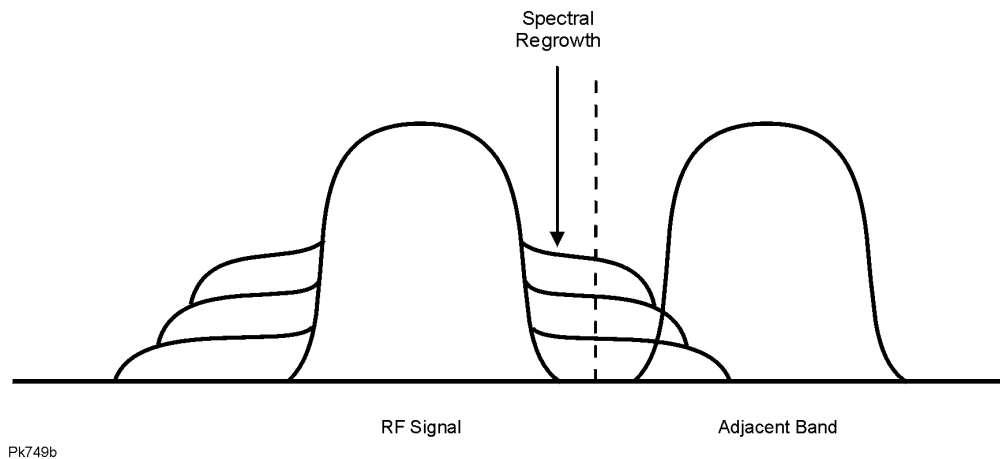

How Clipping Reduces Peak-to-Average Power

You can reduce peak-to-average power, and consequently spectral regrowth, by clipping the waveform to a selected percentage of its peak power. The ESG signal generator provides two different methods of clipping: circular and rectangular.

During *circular* clipping, clipping is applied to the combined I and Q RF waveform ($|I + jQ|$). Notice in [Figure 4-13](#) that the clipping level is constant for all phases of the vector representation and appears as a circle. During *rectangular* clipping, clipping is applied to the I and Q waveforms separately ($|I|, |Q|$). Notice in [Figure 4-14](#) that the clipping level is different for I and Q; therefore, it appears as a rectangle in the vector representation. With either method, the objective is to clip the waveform to a level that effectively reduces spectral regrowth, but does *not* compromise the integrity of the signal. [Figure 4-15](#) uses two complementary cumulative distribution plots to show the reduction in peak-to-average power that occurs after applying circular clipping to an RF waveform.

The lower you set the clipping value, the lower the peak power that is passed (or the more the signal is clipped). Often, the peaks can be clipped successfully without substantially interfering with the rest of the waveform. Data that might be lost in the clipping process is salvaged because of the error correction inherent in the coded systems. If you clip too much of the waveform, however, lost data is irrecoverable. You may have to try several clipping settings to find a percentage that works well.

Figure 4-13 Circular Clipping

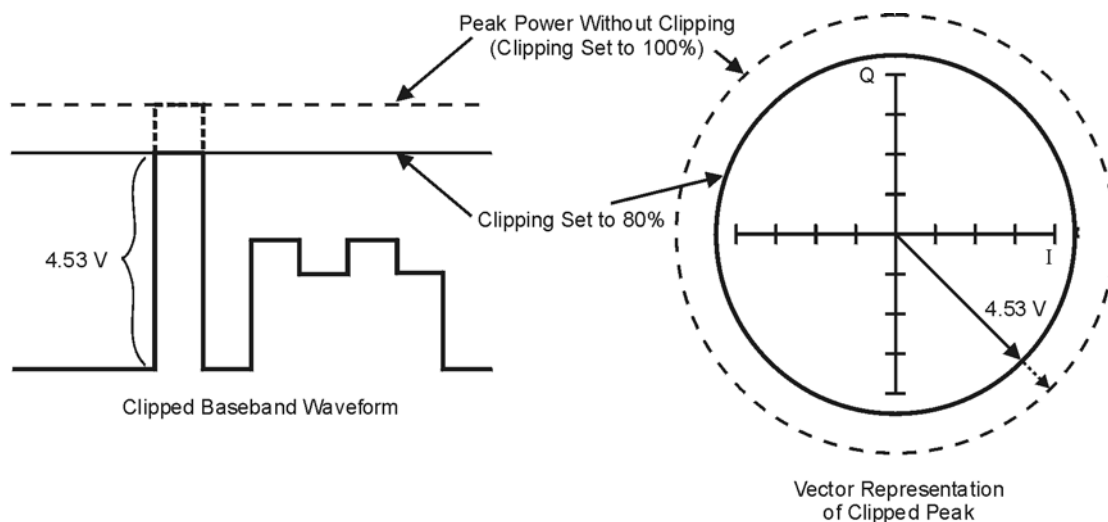

Pk748b

Figure 4-14 Rectangular Clipping

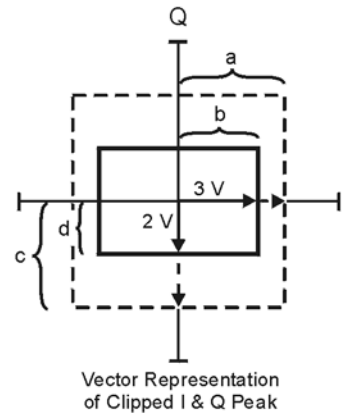
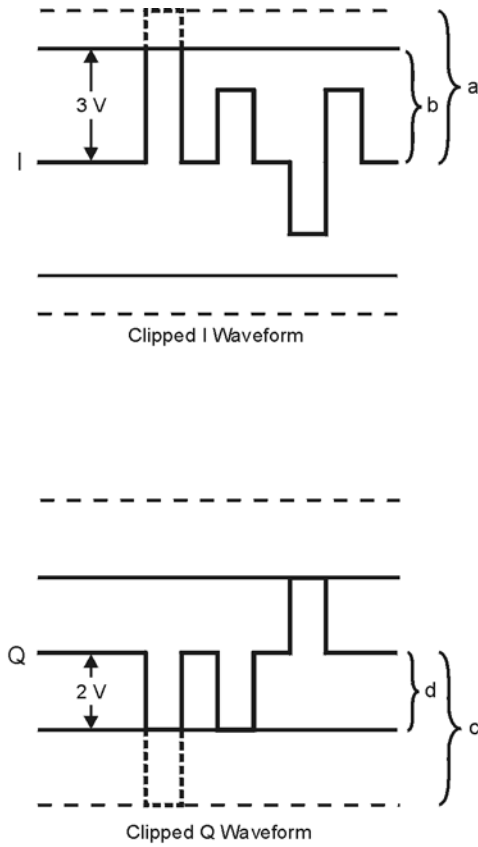

- a) $|I|$ Clipping Set to 100% (No Clipping)
- b) $|I|$ Clipping Set to 75% of Greatest Peak
- c) $|Q|$ Clipping Set to 100% (No Clipping)
- d) $|Q|$ Clipping Set to 50% of Greatest Peak

pk751b

Figure 4-15 Reduction of Peak-to-Average Power

Complementary Cumulative Distribution

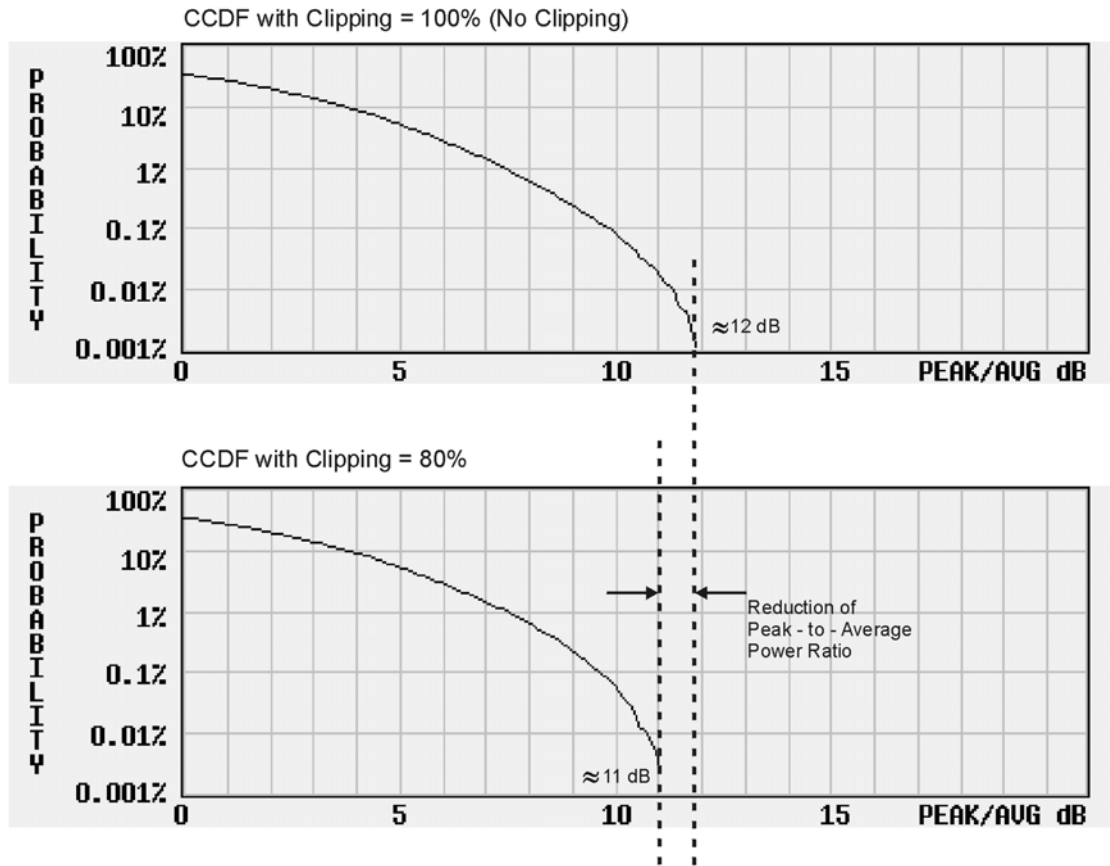

Pk734b

FIR Filtering Options

The ESG signal generator allows you to choose whether clipping occurs prior to, or after, FIR filtering. Because clipped waveforms have abrupt discontinuities which can generate noise, you can select *pre*-FIR filter clipping. The FIR filter smooths any discontinuities in the clipped waveform and prevents noise. If desired, however, you can also select *post*-FIR filter clipping.

How Clipping Differs from Symbol Offset

Another method used to control the power peak problem is to modify the symbol-offset values of the channels that comprise either the I or Q waveform. This is accomplished by using the signal generator's W-CDMA channel table editor. Unlike clipping, which reduces existing peaks, this method attempts to *prevent* peaks.

When multiple channels use a framing structure in which certain bits are designed to have the same state, these bits align and are summed to create power peaks. Offsetting the symbols in the channels prevents these bits from aligning, creating a cancelling effect. You can experiment with using the symbol-offset method in combination with clipping.

Calculating Downlink Scramble Codes

The Option 100 signal generator implements scrambling codes for downlink channels in compliance with the 3GPP 3.1 specification. This is done through the use of Scramble Code, Scramble Type, and Scramble Offset fields in the downlink Edit Channel Setup table editor. These fields are linked so that an entry to any field affects the actual scramble code. To better understand the relationship, please refer to the following formula.

$$n = (16 \times i) + k + m$$

Where n = scramble code

Range: 0 to 24575

i = scramble code field input

Primary: Range 0 to 511

Secondary: Range 0 to 511

k = scramble offset field input

Range: 0 to 15

m = scramble type field input

Standard: adds 0

Right Alternate: adds 16384

Left Alternate: adds 8192

The screenshot shows a software interface for configuring a channel. At the top, it displays 'FREQUENCY' as 4.000 000 000 00 GHz and 'AMPLITUDE' as -135.00 dBm. Below this, there are buttons for 'RF OFF' and 'RF ON'. A table lists channel configurations with columns for Type, Rate ksp/s, Spread Code, Power dB, tDPCH Offset, TFCI, TPC, Scramble Code, Scramble Type, and Scramble Offset. The table contains 5 rows of data. To the right of the table are control buttons: 'Edit Item', 'Insert Row', 'Delete Row', 'Adjust Code Domain Power', and 'Goto Row'. At the bottom right, it says 'More (1 of 2)'.

| Type | Rate ksp/s | Spread Code | Power dB | tDPCH Offset | TFCI | TPC | Scramble Code | Scramble Type | Scramble Offset | |
|------|------------|-------------|----------|--------------|------|-----|---------------|---------------|-----------------|---|
| 1 | PCCPCH | 15.0 | 1 | -9.02 | N/A | N/A | N/A | 6 | STD | 0 |
| 2 | SSCH | 15.0 | N/A | -12.02 | N/A | N/A | N/A | 8 | STD | 7 |
| 3 | CPICH | 15.0 | 0 | -9.02 | N/A | N/A | N/A | 6 | RGT | 7 |
| 4 | DPCH | 30.0 | 8 | -6.02 | 0 | 0 | 5555 | 8 | LFT | 7 |
| 5 | | | | | | | | | | |

pk764b

The Scramble Code field has two sets: primary and secondary, each with a field range of 0 through 511. The primary and secondary sets are determined by the Scramble Offset field. If the Scramble Offset field is zero, then the scramble code is in the primary set. Any non-zero entry enables the secondary set. The Scramble Offset field has a range of 0 through 15.

The Scramble Type field has three modes: Standard, Right Alternate, and Left Alternate. The standard scramble type has a value of zero and does not contribute to the scramble code. Selecting the right alternate adds 16384 to the actual scramble code, whereas the left alternate adds 8192.

Scramble Codes with Standard Scramble Type

A primary scramble code is the product of the Scramble Code field entry and 16. Therefore, the primary scramble code set contains all multiples of 16 from 0 through 8176.

A secondary scramble code is the sum of the non-zero Scramble Offset field entry and the primary scramble code. The secondary scramble code set uses the numbers in between the multiples of 16.

Thus, all numbers from 0 through 8191 are available for scramble codes when using the standard scramble type.

Refer to the following for examples of scramble codes generated with the primary and secondary sets:

$$n = (16 \times i) + k + m$$

Where n = scramble code

i = scramble code field input

k = scramble offset field input

m = scramble type field input

A: Primary set

i = 6
k = 0
m = 0
n = 96

B: Secondary set

i = 8
k = 7
m = 0
n = 135

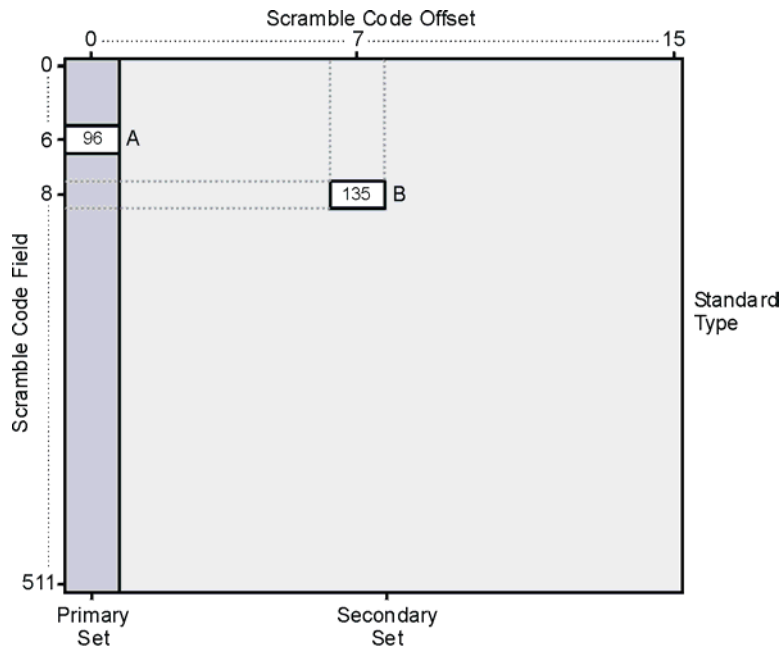

pk765t

Scramble Codes with Right and Left Alternate Scramble Types

Recalling that right alternate adds 16384 to the scramble code and left alternate adds 8192, refer to the following examples of scramble codes generated with the right alternate and left alternate scramble types:

$$n = (16 \times i) + k + m$$

Where n = scramble code

- i = scramble code field input
- k = scramble offset field input
- m = scramble type field input

A: Primary set + Left Alternate

- i = 6
- k = 0
- m = 8192
- n = 8288

B: Secondary set + Right Alternate

- i = 8
- k = 7
- m = 16384
- n = 16519

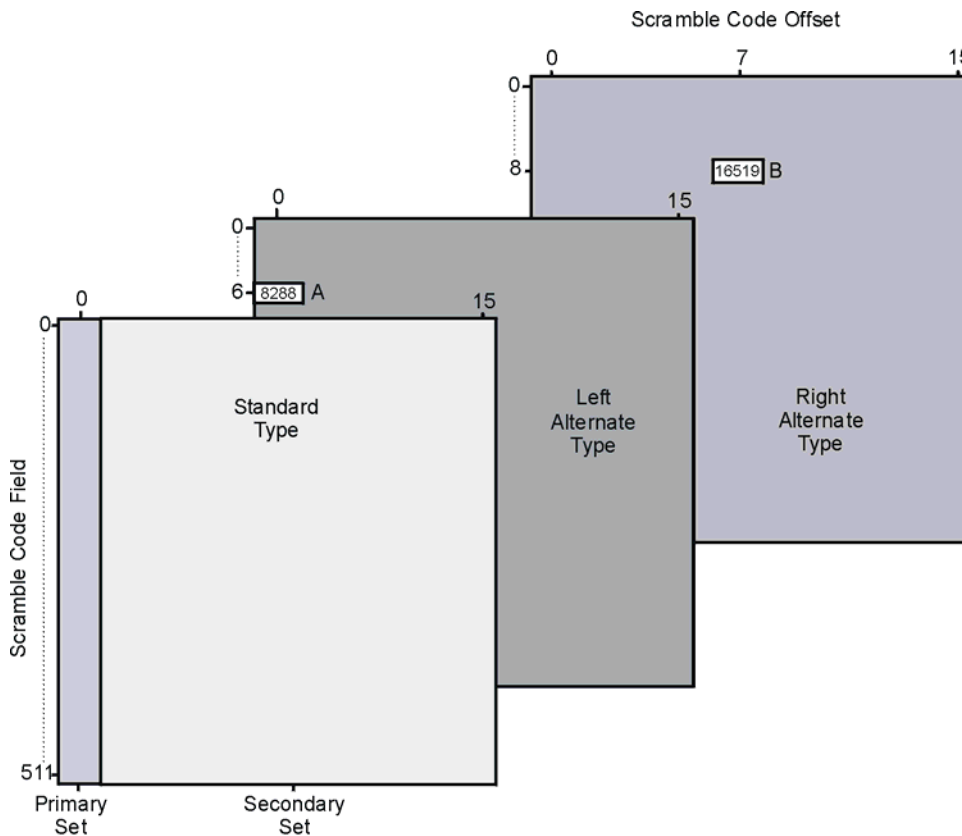

pk766t

5 Remote Programming

This chapter describes W-CDMA subsystem SCPI commands. The descriptions include syntax requirements, ranges, restrictions, and status after a *RST.

W-CDMA Subsystem SCPI Command Reference

Use the following SCPI commands to remotely set the controls and parameters associated with the W-CDMA (3GPP 3.5 2001-03) communications standard. These commands apply only to signal generators with both Options UND and 100.

Apply Waveform

```
[ :SOURce ]:RADio:WCDMa:TGPP:ARB:LINK:DOWN:SETup:TABLE:APPLY
```

Execute this command to generate a W-CDMA signal based on the current values in the W-CDMA channel setup table editor.

ARB Reference Internal External

```
[ :SOURce ]:RADio:ARB:CLOCK:REFeRence[ :SOURce ] INTernal|EXTernal  
[ :SOURce ]:RADio:ARB:CLOCK:REFeRence[ :SOURce ]?
```

Execute this command to select either an internal or external reference for the waveform clock. If external is selected, the external frequency *must* be entered (see the Reference Frequency command) and the signal must be applied to the BASEBAND GEN REF IN connector.

*RST Value: Internal.

Channel Setup

Downlink Channels

```
[ :SOURce ]:RADio:WCDMa:TGPP:ARB:LINK:DOWN:SETup:TABLE:  
CHANnel INIT|APPend|<chan_num>,<chan_type>,<symbol_rate>,<spread_code>,  
<power>,<tDPCH_offset>,<TFCI>,<TPC>,<scramble_code>,<scramble_type>,  
<scramble_offset>,<data_val>,<TFCI_power>,<TPC_power>,<pilot_power>,  
<pilot_bits>  
[ :SOURce ]:RADio:WCDMa:TGPP:ARB:LINK:DOWN:SETup:TABLE:CHANnel? <chan_num>  
[ :SOURce ]:RADio:WCDMa:TGPP:ARB:LINK:DOWN:SETup:TABLE:NCHANnel?
```

These commands define the channel parameters of the W-CDMA signal. Use `INIT` to clear the table editor and define the parameters for the first channel; use `APPEND` to add new channels. To edit an existing channel, use its channel number (`<chan_num>`). Refer to [Table](#) on page 5-3 for definitions, choices, and ranges for each downlink channel parameter.

Downlink Channel Parameters

| Parameter | Definition | Choices/Range |
|-------------------|---|---|
| <chan_type> | sets the channel type | PCCPCH, SCCPCH, PSCH, SSCH, DPCH, CPICH, PICH, or OCNS |
| <symbol_rate> | sets the symbol rate | 7500 to 960000 (symbols per second) |
| <spread_code> | sets the spread code | Symbol Rate 7.5 ksp/s 0 to 511 15.0 ksp/s 0 to 255 30.0 ksp/s 0 to 127 60.0 ksp/s 0 to 63 120.0 ksp/s 0 to 31 240.0 ksp/s 0 to 15 480.0 ksp/s 0 to 7 960.0 ksp/s 0 to 3 |
| <power> | sets the power level for the channel | -40dB to 0dB |
| <tDPCH_offset> | sets the symbol offset for the channel | 0 to 149 |
| <TFCI> | transport format combination indicator | 0 to 1023 |
| <TPC> | transmit power control | 0000 to 7FFF |
| <scramble_code> | sets the scramble code value | 0 to 511 |
| <scramble_type> | sets the scramble type | STANdard, RALternate, LALternate |
| <scramble_offset> | sets the scramble offset value | 0 to 15 |
| <data_val> | sets the data value for channel type: PICH others | RANDom, PN9, PINDicator, or 00000000 to 11111111 RANDom, PN9 or 00000000 to 11111111 |
| <TFCI_power> | power offset | -20dB to 20dB |
| <TPC_power> | power offset | -20dB to 20dB |
| <pilot_power> | power offset | -20dB to 20dB |
| <pilot_bits> | number of pilot bits that will be in the DPCH channel | Symbol Rate 7.5 ksp/s 4 15.0 ksp/s 2, 4, 8 30.0 ksp/s 4, 8 60.0 ksp/s 8 120.0 ksp/s 8 >240.0 ksp/s 16 |

Uplink Channels

```
[ :SOURce]:RADio:WCDMa:TGPP:ARB:LINK:UP:SETup:TABLE:
CHANnel INIT|APPend|<chan_num>,<chan_type>,<symbol_rate>,<spread_code>,
<power>,<TFCI>,<TPC>,<data_val>,<fbi_bits_count>,<fbi_bits_value>
```

```
[ :SOURce]:RADio:WCDMa:TGPP:ARB:LINK:UP:SETup:TABLE:CHANnel? <chan_num>
```

```
[ :SOURce]:RADio:WCDMa:TGPP:ARB:LINK:UP:SETup:TABLE:NCHANnel?
```

These commands define the channel parameters of the W-CDMA signal. Use `INIT` to clear the table editor and define the parameters for the first channel; use `APPend` to add new channels. To edit an existing channel, use its channel number (`<chan_num>`). Refer to [Table 5-1](#) on page 5-4 for definitions, choices, and ranges for each uplink channel parameter.

Table 5-1 Uplink Channel Parameters

| Parameter | Definition | Choices/Range |
|------------------|--|---|
| <chan_type> | sets the channel type | DPCCH or DPDCH |
| <symbol_rate> | sets the symbol rate for the channel type: DPCCH DDPCH | 15.0 ksps 15.0 to 960 ksps |
| <spread_code> | sets the spread code | Symbol Rate 7.5 ksps 0 to 511 15.0 ksps 0 to 255 30.0 ksps 0 to 127 60.0 ksps 0 to 63 120.0 ksps 0 to 31 240.0 ksps 0 to 15 480.0 ksps 0 to 7 960.0 ksps 0 to 3 |
| <power> | sets the power level for the channel | -40db to 0dB |
| <TFCI> | transport format combination indicator | 0 to 1023 |
| <TPC> | transmit power control | 0000 to 7FFF |
| <data_val> | sets the data value | RANDom or 00000000 to 11111111 |
| <FBI_bits_count> | number of FBI bits | 0 to 2 |
| <FBI_bits_value> | value of FBI bits | 0 to 3 |

Chip Rate

```
[ :SOURce ] :RADio:WCDMa:TGPP:ARB:CRATE <value>  
[ :SOURce ] :RADio:WCDMa:TGPP:ARB:CRATE?
```

Execute this command to set the chip rate. Choices for the variable <value> are 3.84 Mcps \pm 10%.

*RST Value: 3.840000 Mcps

Clipping Level, |I+jQ|

```
[ :SOURce ] :RADio:WCDMa:TGPP:ARB:CLIPping[I:JQ] <10-100%>  
[ :SOURce ] :RADio:WCDMa:TGPP:ARB:CLIPping[I:JQ]?
```

Execute this command to clip (limit) the modulation level of the combined I and Q waveform to a percentage of full scale. A level of 100.0% equates to no clipping.

*RST Value: 100.0%

Clipping Level, |I|

```
[ :SOURce ] :RADio:WCDMa:TGPP:ARB:CLIPping:I <10-100%>  
[ :SOURce ] :RADio:WCDMa:TGPP:ARB:CLIPping:I?
```

Execute this command to clip (limit) the modulation level of the waveform's I component to a percentage of full scale. A level of 100.0% equates to no clipping.

*RST Value: 100.0%

Clipping Level, |Q|

```
[ :SOURce ] :RADio:WCDMa:TGPP:ARB:CLIPping:Q <10-100%>  
[ :SOURce ] :RADio:WCDMa:TGPP:ARB:CLIPping:Q?
```

Execute this command to clip (limit) the modulation level of the waveform's Q component to a percentage of full scale. A level of 100.0% equates to no clipping.

*RST Value: 100.0%

Clipping, Pre/Post FIR Filter

```
[ :SOURce ] :RADio:WCDMa:TGPP:ARB:CLIPping:POSition PRE|POST  
[ :SOURce ] :RADio:WCDMa:TGPP:ARB:CLIPping:POSition?
```

Execute this command to select whether you want the waveform to be clipped before (PRE) or after (POST) FIR filtering.

*RST Value: PRE

Clipping, Type

```
[ :SOURce]:RADio:WCDMa:TGPP:ARB:CLIPping:TYPE IJQ|IORQ  
[ :SOURce]:RADio:WCDMa:TGPP:ARB:CLIPping:TYPE?
```

Execute this command to select either `IJQ` or `IORQ` as the clipping type. If you select `IJQ`, the combined I and Q waveform will be clipped (*circular* clipping). If you select `IORQ`, the I and Q components of the waveform are clipped independently (*rectangular* clipping). In this case, you can clip I and Q to different levels.

*RST Value: `IJQ`

Code Domain Power

```
[ :SOURce]:RADio:WCDMa:TGPP:ARB:LINK:DOWN:SETup:TABLE:  
PADJust EQUal|SCALE
```

Execute this command to set the code domain power. Available in downlink only.

`EQUal|SCALE` - code domain power settings

`EQUal` - sets the channel power levels so that all channels are of equal energy per bit and the total power equals 0 dBm.

`SCALE` - scales all of the current channel powers so that the total power equals 0 dB while keeping the previous power ratios between the individual channels.

External Trigger Delay State

```
[ :SOURce]:RADio:WCDMa:TGPP:ARB:TRIGger[:SOURce]:EXTernal:DElay:  
STATE ON|OFF|1|0
```

```
[ :SOURce]:RADio:WCDMa:TGPP:ARB:TRIGger[:SOURce]:EXTernal:DElay:STATE?
```

Execute this command to set the operating state for the external trigger delay. The choices are `On` or `Off`.

*RST Value: `Off`

External Trigger Delay Time

```
[ :SOURce]:RADio:WCDMa:TGPP:ARB:TRIGger[:SOURce]:EXTernal:DElay <value>
```

```
[ :SOURce]:RADio:WCDMa:TGPP:ARB:TRIGger[:SOURce]:EXTernal:DElay?
```

Execute this command to set the external trigger delay time. The range of values allowed for the variable `<value>` is 2.000 microseconds through 3600 seconds.

*RST Value: `2.000 msec`

External Trigger Polarity

```
[ :SOURce ] : RADio : WCDMa : TGPP : ARB : TRIGger [ :SOURce ] : EXTeRnal :  
SLOPe POSitive | NEGative
```

```
[ :SOURce ] : RADio : WCDMa : TGPP : ARB : TRIGger [ :SOURce ] : EXTeRnal : SLOPe ?
```

Execute this command to set the polarity of the external trigger. The choices are positive or negative.

*RST Value: negative

Filter Alpha

```
[ :SOURce ] : RADio : WCDMa : TGPP : ARB : FILTer : ALPHa <value>  
[ :SOURce ] : RADio : WCDMa : TGPP : ARB : FILTer : ALPHa ?
```

Execute this command to change the Nyquist or root Nyquist filter's alpha value. The acceptable range for the variable <value> is 0.000 through 1.000.

This command is effective only *after* choosing a root Nyquist or Nyquist filter. It does not have an effect on other types of filters.

*RST Value: 0.500

Filter BbT

```
[ :SOURce ] : RADio : WCDMa : TGPP : ARB : FILTer : BBT <value>  
[ :SOURce ] : RADio : WCDMa : TGPP : ARB : FILTer : BBT ?
```

Execute this command to change the bandwidth-multiplied-by-bit-time (BbT) filter parameter. The acceptable range for the variable <value> is 0.000 through 1.000.

This command is effective only with a Gaussian filter. It does not have an effect on other types of filters.

*RST Value: 0.500

Filter Optimization

```
[ :SOURce ] : RADio : WCDMa : TGPP : ARB : FILTer : CHANnel EVM | ACP  
[ :SOURce ] : RADio : WCDMa : TGPP : ARB : FILTer : CHANnel ?
```

Execute this command to optimize the filter for minimized error vector magnitude (select EVM) or to minimized adjacent channel power (select ACP). The EVM selection provides the most ideal passband. The ACP selection improves stopband rejection.

This feature only applies to root Nyquist, Nyquist, and Gaussian filters.

*RST Value: EVM

Filter Selection

```
[ :SOURce]:RADio:WCDMa:TGPP:ARB:FILTer RNYQuist|NYQuist|GAUSSian|  
RECTangle|WCDMA|IS95|IS95_EQ|IS95_MOD|IS95_MOD_EQ|IS2000SR3DS|UGGaussian|AC4Fm|  
"<file name>"
```

```
[ :SOURce]:RADio:WCDMa:TGPP:ARB:FILTer?
```

Execute this command to select the pre-modulation filter type. The choices are:

RNYQuist - root Nyquist filter

NYQuist - Nyquist filter

GAUSSian - Gaussian filter

RECTangle - Rectangle filter

WCDMA - 0.22 Nyquist filter optimized for ACP

IS95 - Standard IS-95 filter

IS95_MOD - a modified version of an IS-95 filter which meets the IS-95 error function for improved adjacent channel performance.

IS95_EQ - a modified version of an IS-95 filter with an equalizer which provides base station phase equalization for the transmit signal path.

IS95_MOD_EQ - a modified version of an IS-95 filter which meets the IS-95 error function for improved adjacent channel performance with an equalizer which provides base station phase equalization for the transmit signal path.

IS2000SR3DS - a modified IS-2000 spreading rate 3 direct spread filter

UGGaussian - UN3/4 delay compatible, 0.300 fixed BbT, GSM Gaussian

AC4Fm - APCO 25 specified C4FM filter

"<file name>" - any filter file that you have either created externally and downloaded into memory, or that you have created internally in the Define User FIR menu and then subsequently stored.

*RST Value: WCDMA

Gain Unit

```
[ :SOURce]:RADio:WCDMa:TGPP:ARB:LINK:UP:SETup:TABLE:GUNit DB|LINear|INDEX  
[ :SOURce]:RADio:WCDMa:TGPP:ARB:LINK:UP:SETup:TABLE:GUNit?
```

Execute this command to set the gain unit in the uplink channel. The choices are dB, signaling indexes, or linear ratios. Uplink table power will then be set and read in the gain unit.

Gate Active

```
[ :SOURCE ] :RADio:WCDMa:TGPP:ARB:TRIGger:TYPE:GATE:ACTive LOW|HIGH
[ :SOURCE ] :RADio:WCDMa:TGPP:ARB:TRIGger:TYPE:GATE:ACTive?
```

Execute this command to toggle the polarity of the “through” or active state of a gated trigger signal. The choices are low or high. Gate active low will output the trigger signal while the gate is low at the PATTERN TRIG IN connector. Gate active high has the opposite effect, outputting the trigger signal while the signal level at the PATTERN TRIG IN connector is in a high state.

I/Q Mapping

```
[ :SOURCE ] :RADio:WCDMa:TGPP:ARB:IQMap NORMAL|INVert|INVerted
[ :SOURCE ] :RADio:WCDMa:TGPP:ARB:IQMap?
```

Execute this command to select whether the I/Q outputs will be normal or inverted.

*RST Value: Normal

Link Direction

```
[ :SOURCE ] :RADio:WCDMa:TGPP:ARB:LINK DOWN|UP
[ :SOURCE ] :RADio:WCDMa:TGPP:ARB:LINK?
```

Use this command to select a W-CDMA downlink or uplink channel configuration.

Multicarrier, Define

```
[ :SOURCE ] :RADio:WCDMa:TGPP:ARB:LINK:DOWN:SETup:MCARrier:TABLE INIT|APPend|
<carrier_num>,DPCH1|DPCH3|PPSCH|PPDPCH1|PPDPCH3|TM1D16|TM1D32|
TM1D64|TM2|TM3D16|TM3D32|TM4|"<file name>",<freq_offset>,<power>
[ :SOURCE ] :RADio:WCDMa:TGPP:ARB:LINK:DOWN:SETup:MCARrier:
TABLE? <carrier_num>
[ :SOURCE ] :RADio:WCDMa:TGPP:ARB:LINK:DOWN:SETup:MCARrier:TABLE:
NCARriers?
```

This command defines the multicarrier W-CDMA waveform. Use `INIT` to clear the table editor and define the parameters for the first carrier. Use `APPEND` to add new up to four new carriers.

<carrier_num> - specifies the carrier number to modify

DPCH1 - 1 DPCH downlink channel

DPCH3 - 3 DPCH downlink channels

PPSCH - PCCPCH + SCH downlink channel

PPDPCH1 - PCCPCH + SCH + CPICH plus 1 DPCH downlink channel

PPDPCH3 - PCCPCH + SCH + CPICH plus 3 DPCH downlink channels

TM1D16 - a Test Model 1 with 16 DPCH downlink channels

TM1D32 - a Test Model 1 with 32DPCH downlink channels

TM1D64 - a Test Model 1 with 64 DPCH downlink channels

TM2 - a Test Model 2 downlink channel

TM3D16 - a Test Model 3 with 16 DPCH downlink channels

TM3D32 - a Test Model 3 with 32 DPCH downlink channels

TM4 - a Test Model 4 downlink channel

"<file name>" - a custom multicarrier W-CDMA waveform stored in the signal generator's memory. This value is entered only for a custom carrier.

<freq_offset> - the frequency offset in hertz.

<power> - the power level in dB

Multicarrier, Select Setup

```
[ :SOURce]:RADio:WCDMa:TGPP:ARB:LINK:DOWN:SETup:
MCArrier CAR2|CAR3|CAR4|"<file name>"
```

```
[ :SOURce]:RADio:WCDMa:TGPP:ARB:LINK:DOWN:SETup:MCArrier?
```

This command defines the type of multicarrier W-CDMA setup. The choices include:

CAR2 - a standard 2-carrier setup with the following settings:

Carrier 1: PCCPC + SCH, -7.5 MHz frequency offset, 0 dB power

Carrier 2: PCCPC + SCH, 7.5 MHz frequency offset, 0 dB power

CAR3 - a standard 3-carrier setup with the following settings:

Carrier 1: PCCPC + SCH, -5 MHz frequency offset, 0 dB power

Carrier 2: PCCPC + SCH, 0 kHz frequency offset, 0 dB power

Carrier 3: PCCPC + SCH, 5 MHz frequency offset, 0 dB power

CAR4 - a standard 4-carrier setup with the following settings:

Carrier 1: PCCPC + SCH, -7.5 MHz frequency offset, 0 dB power

Carrier 2: PCCPC + SCH, -2.5 MHz frequency offset, 0 dB power

Carrier 3: PCCPC + SCH, 2.5 MHz frequency offset, 0 dB power

Carrier 4: PCCPC + SCH, 7.5 MHz frequency offset, 0 dB power

"<file name>" - a user-defined multicarrier W-CDMA state file stored in non-volatile memory.

*RST Value: 2 Carriers

Multicarrier, Store Custom

```
[ :SOURce ]:RADio:WCDMA:TGPP:ARB:LINK:DOWN:SETup:MCARrier:  
STORe "<file name>"
```

This command stores the current multicarrier setup information into the memory catalog under the file name you entered:

The following instrument state information is stored into the memory catalog:

- type of carriers
- frequency offset for each carrier
- power level for each carrier

NOTE To recall these custom multicarrier settings from memory, execute this command: [:SOURce]:RADio:WCDMA:TGPP:ARB:LINK:DOWN:SETup:MCARrier "<file name>"

Reconstruction Filter

```
[ :SOURce ]:RADio:ARB:RFILter <value>|THROugh  
[ :SOURce ]:RADio:ARB:RFILter?
```

Execute this command to modify the reconstruction filter. You may choose a filter with a cutoff frequency of 250.0 kHz, 2.500 MHz, 8.000 MHz or no filter (Through). Acceptable values for the variable <value> are 250.0 kHz, 2.500 MHz, or 8.000 MHz.

*RST Value: 2.500 MHz

Reference Frequency

```
[ :SOURce ]:RADio:ARB:CLOCK:REFerence:EXTernal:FREQuency <value>  
[ :SOURce ]:RADio:ARB:CLOCK:REFerence:EXTernal:FREQuency?
```

This command sets the reference frequency of the external clock. It is effective only when an external reference is applied to the BASEBAND GEN REF IN connector. The acceptable range for the variable <value> is 250.0000 kHz to 20.0000000 MHz.

*RST Value: 10.0000000 MHz

Retrigger Mode State

```
[ :SOURce ]:RADio:WCDMa:TGPP:ARB:RETRigger ON|OFF|1|0  
[ :SOURce ]:RADio:WCDMa:TGPP:ARB:RETRigger?
```

This command sets the operating state of the retrigger mode. The choices are On or Off.

*RST Value: On

Revision Query

```
[ :SOURce]:RADio:WCDMa:TGPP:ARB:REVision?
```

This command checks the version for the arbitrary waveform generator firmware.

Scramble Code

```
[ :SOURce]:RADio:WCDMa:TGPP:ARB:LINK:UP:SCRamble <value>  
[ :SOURce]:RADio:WCDMa:TGPP:ARB:LINK:UP:SCRamble?
```

Execute this command to enter the value that you want for the scramble code for all uplink channels.

Range: 0 through FFFFFFFF

*RST Value: 0

Second DPDCH Setup

```
[ :SOURce]:RADio:WCDMa:TGPP:ARB:LINK:UP:SDPDch I|Q  
[ :SOURce]:RADio:WCDMa:TGPP:ARB:LINK:UP:SDPDch?
```

Execute this command to set the second DPDCH channel to I or Q. Subsequent channels will alternate accordingly between I and Q.

*RST Value: Q

TFCI Field State

```
[ :SOURce]:RADio:WCDMa:TGPP:ARB:LINK:DOWN:TFCI ON|OFF|1|0  
[ :SOURce]:RADio:WCDMa:TGPP:ARB:LINK:DOWN:TFCI?  
[ :SOURce]:RADio:WCDMa:TGPP:ARB:LINK:UP:TFCI ON|OFF|1|0  
[ :SOURce]:RADio:WCDMa:TGPP:ARB:LINK:UP:TFCI?
```

Execute this command to turn the TFCI (Transport Format Combination Indicator) field On or Off for all the channels in the current table editor.

*RST Value: On

Trigger Source

```
[ :SOURce]:RADio:WCDMa:TGPP:ARB:TRIGger[:SOURce] KEY|EXT|BUS  
[ :SOURce]:RADio:WCDMa:TGPP:ARB:TRIGger[:SOURce]?
```

Execute this command to select the trigger source. The choices include the front panel **Trigger** key, a trigger command sent over the GPIB bus, or an external trigger applied to the PATTERN TRIG IN connector.

*RST Value: Ext

Trigger Type

```
[ :SOURce ] :RADio:WCDMa:TGPP:ARB:TRIGger:TYPE CONTinuous | SINGLE | GATE
[ :SOURce ] :RADio:WCDMa:TGPP:ARB:TRIGger:TYPE?
```

Execute this command to select the trigger type. The choices are continuous, single, gated, and when a waveform sequence is active, segment advance.

*RST Value: Continuous

User FIR Definition

```
MEMory:DATA:FIR "<file name>",osr,coefficient{,coefficient}
MEMory:DATA:FIR? "<file name>"
```

This command defines User FIR filters. Although the maximum filter length is 1024 coefficients, with a maximum oversampling ratio of 32, an FIR filter for use in W-CDMA must not have more than 256 coefficients; select the number of symbols and the oversample ratio accordingly. Examples of using the FIR table editor are provided in [Chapter 2, “Using Functions.”](#)

Setting the Oversample Ratio

The oversample ratio (OSR) is the number of filter taps per symbol. Acceptable values range from 1 through 32/ Although the maximum combination of symbols and oversampling ratio allowed by the table editor is 1024, the instrument hardware is limited to 32 symbols, an oversample ratio between 4 and 16, and 256 coefficients. If you enter more than 32 symbols or 256 coefficients, the instrument will be unable to use the filter. If the oversample ratio is different from the internal, optimally selected one, the filter is automatically resampled to an optimal oversample ratio.

W-CDMA Link Setup

```
[ :SOURce ] :RADio:WCDMa:TGPP:ARB:LINK:DOWN:SETup DPCH1 | DPCH3 | PPSCH | PPDPCH1 |
PPDPCH3 | TM1D16 | TM1D32 |
TM1D64 | TM2 | TM3D16 | TM3D32 | TM4 | MCArrier | "<file name>"
```

```
[ :SOURce ] :RADio:WCDMa:TGPP:ARB:LINK:DOWN:SETup?
```

```
[ :SOURce ] :RADio:WCDMa:TGPP:ARB:LINK:UP:SETup DPCCH | DDPDCH1 | DDPDCH2 | DDPDCH3 |
DDPDCH4 | DDPDCH5 | "<file name>"
```

```
[ :SOURce ] :RADio:WCDMa:TGPP:ARB:LINK:UP:SETup?
```

Execute this command to select a pre-defined channel configuration for the W-CDMA downlinks or uplinks. You can select a pre-defined channel setup, or select a stored custom W-CDMA state. The command is also used to activate multicarrier mode (see also [“Multicarrier, Select Setup”](#) on page 5-10).

Downlink setup selections:

- DPCH1 - 1 DPCH downlink channel
- DPCH3 - 3 DPCH downlink channels

PPSCH - PCCPCH plus SCH downlink channels
PPDPCH1 - PCCPCH plus SCH plus 1 DPCH downlink channels
PPDPCH3 - PCCPCH plus SCH plus 3 DPCH downlink channels
TM1D16 - a Test Model 1 with 16 DPCH downlink channels
TM1D32 - a Test Model 1 with 32 DPCH downlink channels
TM1D64 - a Test Model 1 with 64 DPCH downlink channels
TM2 - a Test Model 2 downlink channel
TM3D16 - a Test Model 3 with 16 DPCH downlink channels
TM3D32 - a Test Model 3 with 32 DPCH downlink channels
TM4 - a Test Model 4 downlink channel
MCArrier - activates multicarrier mode
"<file name>" - a stored custom W-CDMA state

*RST Value: a single DPCH downlink channel

Uplink setup selections:

DPCCH - a single DPCCH channel
DDPDCH1 - a DPCCH plus one DPDCH channel
DDPDCH2 - a DPCCH plus two DPDCH channels
DDPDCH3 - a DPCCH plus three DPDCH channels
DDPDCH4 - a DPCCH plus four DPDCH channels
DDPDCH5 - a DPCCH plus five DPDCH channels
"<file name>" - a stored custom W-CDMA state

*RST Value: a single DPCCH uplink channel

W-CDMA State, On/Off

```
[ :SOURce]:RADio:WCDMa:TGPP:ARB[:STATe] ON|OFF|1|0  
[:SOURce]:RADio:WCDMa:TGPP:ARB[:STATe]?
```

Execute this command to enable or disable the W-CDMA capability. The choices are On (1) or Off (0). Executing the command `[:SOURce]:RADio:WCDMa:TGPP:ARB[:STATe] ON` sets up the internal hardware to generate the currently selected W-CDMA signal selection. The W-CDMA and I/Q annunciators are turned on in the display.

Although the digital modulation is enabled with this command, the modulation is not present on the RF carrier until you have executed the command:

```
OUTPut:MODulation[:STATe] ON.
```

*RST Value: Off

W-CDMA State, Store Custom

```
[ :SOURce]:RADio:WCDMa:TGPP:ARB:LINK:DOWN:SETup:  
STORE "<file name>"  
[ :SOURce]:RADio:WCDMa:TGPP:ARB:LINK:UP:SETup:  
STORE "<file name>"
```

Execute this command to store the current custom W-CDMA state into a designated file name. Afterward, you can recall this custom state from the signal generator's memory by executing the command `[:SOURce]:RADio:WCDMa:TGPP:ARB:LINK:DOWN:SETup "<file name>"`, or `[:SOURce]:RADio:WCDMa:TGPP:ARB:LINK:UP:SETup "<file name>"` (with the appropriate file name in place of the variable).

Along with the contents of the W-CDMA channel table editor (channel types, spread code, scramble code, power levels, symbol rate, symbol offset, and data pattern), this command stores the following instrument state information to the memory catalog:

- FIR filter
- FIR filter file name
- FIR filter alpha and BbT
- FIR filter channel (EVM or ACP)
- IQ Mapping
- Link
- Chip rate
- ARB reconstruction filter
- ARB reference clock source (internal or external)
- Clipping
- Downlink TFCI on/off
- Uplink TFCI on/off
- Uplink Second DPDCH I or Q
- Uplink scramble code

6 Programming Command Cross-Reference

This chapter lists the W-CDMA softkeys and their corresponding SCPI commands. For a complete list of the signal generator hardkeys and softkeys and their corresponding SCPI commands, please refer to the programming guide.

Mode – W-CDMA Softkeys

| Key | SCPI Command |
|---|---|
| 1DPCH | [:SOURce]:RADio:WCDMa:TGPP:ARB:LINK:DOWN:SETup DPCH1 [:SOURce]:RADio:WCDMa:TGPP:ARB:LINK:DOWN:SETup? |
| 2 Carriers | [:SOURce]:RADio:WCDMa:TGPP:ARB:LINK:DOWN:SETup: MCARrier CAR2 [:SOURce]:RADio:WCDMa:TGPP:ARB:LINK:DOWN:SETup: MCARrier? |
| 2.500 MHz | [:SOURce]:RADio:ARB:RFILter 2.500 MHz [:SOURce]:RADio:ARB:RFILter? |
| 3 Carriers | [:SOURce]:RADio:WCDMa:TGPP:ARB:LINK:DOWN:SETup: MCARrier CAR3 [:SOURce]:RADio:WCDMa:TGPP:ARB:LINK:DOWN:SETup: MCARrier? |
| 3 DPCH | [:SOURce]:RADio:WCDMa:TGPP:ARB:LINK:DOWN:SETup DPDCH3 [:SOURce]:RADio:WCDMa:TGPP:ARB:LINK:DOWN:SETup? |
| 4 Carriers | [:SOURce]:RADio:WCDMa:TGPP:ARB:LINK:DOWN:SETup: MCARrier CAR4 [:SOURce]:RADio:WCDMa:TGPP:ARB:LINK:DOWN:SETup: MCARrier? |
| 7.5 ksps 15 ksps 30 ksps 60 ksps 120 ksps 240 ksps 480 ksps 960 ksps | [:SOURce]:RADio:WCDMa:TGPP:ARB:LINK:DOWN:SETup: TABLE:CHANnel INIT APPend <chan_num>,<chan_type>, <symbol_rate>,<spread_code>,<power>,<tDPCH_offset>, <TFCI>,<TPC>,<scramble_code>,<scramble_type>, <scramble_offset>,<data_val>,<TFCI_power>,<TPC_power>, <pilot_power>,<pilot_bits> [:SOURce]:RADio:WCDMa:TGPP:ARB:LINK:DOWN:SETup: TABLE:CHANnel? <chan_num> [:SOURce]:RADio:WCDMa:TGPP:ARB:LINK:UP:SETup: TABLE:CHANnel INIT APPend <chan_num>,<chan_type>, <symbol_rate>,<spread_code>,<power>,<TFCI>,<TPC>, <data_val>,<fbi_bits_count>,<fbi_bits_value> [:SOURce]:RADio:WCDMa:TGPP:ARB:LINK:UP:SETup: TABLE:CHANnel? <chan_num> |
| 8.000 MHz | [:SOURce]:RADio:ARB:RFILter 8.0 MHz [:SOURce]:RADio:ARB:RFILter? |
| 250.0 kHz | [:SOURce]:RADio:ARB:RFILter 250 kHz [:SOURce]:RADio:ARB:RFILter? |

| Key | SCPI Command |
|-------------------------------------|--|
| Adjust Code Domain Power | [:SOURce]:RADio:WCDMa:TGPP:ARB:LINK:DOWN:SETup:TABLE:PADJust EQUal SCALE |
| APCO 25 C4FM | [:SOURce]:RADio:WCDMa:TGPP:ARB:FILTer AC4Fm [:SOURce]:RADio:WCDMa:TGPP:ARB:FILTer? |
| Apply Channel Setup | [:SOURce]:RADio:WCDMa:TGPP:ARB:LINK:DOWN:SETup:TABLE:APPLy [:SOURce]:RADio:WCDMa:TGPP:ARB:LINK:UP:SETup:TABLE:APPLy |
| Apply Multicarrier | [:SOURce]:RADio:WCDMa:TGPP:ARB:LINK:DOWN:SETup:TABLE:APPLy |
| ARB Reference Ext Int | [:SOURce]:RADio:ARB:CLOCK:REFerence[:SOURce] INTernal EXTernal [:SOURce]:RADio:ARB:CLOCK:REFerence[:SOURce]? |
| Bus | [:SOURce]:RADio:WCDMa:TGPP:ARB:TRIGger[:SOURce] BUS [:SOURce]:RADio:WCDMa:TGPP:ARB:TRIGger[:SOURce]? |
| Channels | [:SOURce]:RADio:WCDMa:TGPP:ARB:LINK:DOWN:SETup:TABLE:CHANnel INIT APPend <chan_num>,<chan_type>,<symbol_rate>,<spread_code>,<power>,<tdPCH_offset>,<TFCI>,<TPC>,<scramble_code>,<scramble_type>,<scramble_offset>,<data_val>,<TFCI_power>,<TPC_power>,<pilot_power>,<pilot_bits> [:SOURce]:RADio:WCDMa:TGPP:ARB:LINK:DOWN:SETup:TABLE:CHANnel? <chan_num> |
| Chip Rate | [:SOURce]:RADio:WCDMa:TGPP:ARB:CRATe <value> [:SOURce]:RADio:WCDMa:TGPP:ARB:CRATe? |
| Clip I+jQ To | [:SOURce]:RADio:WCDMa:TGPP:ARB:CLIPping[:IJQ] <10-100%> [:SOURce]:RADio:WCDMa:TGPP:ARB:CLIPping[:IJQ]? |
| Clip I To | [:SOURce]:RADio:WCDMa:TGPP:ARB:CLIPping:I <10-100%> [:SOURce]:RADio:WCDMa:TGPP:ARB:CLIPping:I? |
| Clip Q To | [:SOURce]:RADio:WCDMa:TGPP:ARB:CLIPping:Q <10-100%> [:SOURce]:RADio:WCDMa:TGPP:ARB:CLIPping:Q? |
| Clip At PRE POST FIR Filter | [:SOURce]:RADio:WCDMa:TGPP:ARB:CLIPping:POSition PRE POST [:SOURce]:RADio:WCDMa:TGPP:ARB:CLIPping:POSition? |
| Clipping Type I+jQ I , Q | [:SOURce]:RADio:WCDMa:TGPP:ARB:CLIPping:TYPE IJQ IORQ [:SOURce]:RADio:WCDMa:TGPP:ARB:CLIPping:TYPE? |

| Key | SCPI Command |
|----------------------------|---|
| Continuous | [:SOURce]:RADio:WCDMa:TGPP:ARB:TRIGger:TYPE CONT [:SOURce]:RADio:WCDMa:TGPP:ARB:TRIGger:TYPE? |
| CPICH | [:SOURce]:RADio:WCDMa:TGPP:ARB:LINK:DOWN:SETup: TABLE:CHANnel INIT APPend <chan_num>,<chan_type>, <symbol_rate>,<spread_code>,<power>,<tDPCH_offset>, <TFCI>,<TPC>,<scramble_code>,<scramble_type_>, <scramble_offset>,<data_val>,<TFCI_power>,<TPC_power>, <pilot_power>,<pilot_bits> [:SOURce]:RADio:WCDMa:TGPP:ARB:LINK:DOWN:SETup: TABLE:CHANnel? <chan_num> |
| Custom W-CDMA Carrier | [:SOURce]:RADio:WCDMa:TGPP:ARB:LINK:DOWN:SETup: MCArrier:TABLE INIT APPend <carrier_num>,"<file name>",<freq_offset>,<power> [:SOURce]:RADio:WCDMa:TGPP:ARB:LINK:DOWN:SETup: MCArrier:TABLE?<carrier_num> |
| Custom W-CDMA Multicarrier | [:SOURce]:RADio:WCDMa:TGPP:ARB:LINK:DOWN:SETup: MCArrier "<file name>" [:SOURce]:RADio:WCDMa:TGPP:ARB:LINK:DOWN:SETup:MCArrier? |
| Custom W-CDMA State | [:SOURce]:RADio:WCDMa:TGPP:ARB:LINK:DOWN: SETup "<file name>" [:SOURce]:RADio:WCDMa:TGPP:ARB:LINK:DOWN:SETup? [:SOURce]:RADio:WCDMa:TGPP:ARB:LINK:UP:SETup "<file name>" [:SOURce]:RADio:WCDMa:TGPP:ARB:LINK:UP:SETup? |
| Define User FIR | :MEMory:DATA:FIR "<file name>",<osr>,<coefficient { ,coefficient }> :MEMory:DATA:FIR? "<file name>" |
| DPCCH | [:SOURce]:RADio:WCDMa:TGPP:ARB:LINK:UP:SETup DDPDCH [:SOURce]:RADio:WCDMa:TGPP:ARB:LINK:UP:SETup? |
| DPCCH +1 DPDCH | [:SOURce]:RADio:WCDMa:TGPP:ARB:LINK:UP:SETup DDPDCH1 [:SOURce]:RADio:WCDMa:TGPP:ARB:LINK:UP:SETup? |
| DPCCH +2 DPDCH | [:SOURce]:RADio:WCDMa:TGPP:ARB:LINK:UP:SETup DDPDCH2 [:SOURce]:RADio:WCDMa:TGPP:ARB:LINK:UP:SETup? |
| DPCCH +3 DPDCH | [:SOURce]:RADio:WCDMa:TGPP:ARB:LINK:UP:SETup DDPDCH3 [:SOURce]:RADio:WCDMa:TGPP:ARB:LINK:UP:SETup? |
| DPCCH +4 DPDCH | [:SOURce]:RADio:WCDMa:TGPP:ARB:LINK:UP:SETup DDPDCH4 [:SOURce]:RADio:WCDMa:TGPP:ARB:LINK:UP:SETup? |

| Key | SCPI Command |
|--------------------------------|--|
| DPCCH + 5 DPDCH | <pre>[:SOURce]:RADIo:WCDMa:TGPP:ARB:LINK:UP:SETup DDPCH5 [:SOURce]:RADIo:WCDMa:TGPP:ARB:LINK:UP:SETup?</pre> |
| DPCH | <pre>[:SOURce]:RADIo:WCDMa:TGPP:ARB:LINK:DOWN:SETup: TABLE:CHANnel INIT APPend <chan_num>,<chan_type>, <symbol_rate>,<spread_code>,<power>,<tDPCH_offset>, <TFCI>,<TPC>,<scramble_code>,<scramble_type>, <scramble_offset>,<data_val>,<TFCI_power>, <TPC_power>,<pilot_power>,<pilot_bits> [:SOURce]:RADIo:WCDMa:TGPP:ARB:LINK:DOWN:SETup: TABLE:CHANnel? <chan_num></pre> |
| DPDCH Channels | <pre>[:SOURce]:RADIo:WCDMa:TGPP:ARB:LINK:UP:SETup: TABLE:CHANnel INIT APPend <chan_num>,<chan_type>, <symbol_rate>,<spread_code>,<power>,<TFCI>,<TPC>, <data_val>,<fbi_bits_count>,<fbi_bits_value> [:SOURce]:RADIo:WCDMa:TGPP:ARB:LINK:UP:SETup: TABLE:CHANnel? <chan_num></pre> |
| Edit Channel Setup | <pre>[:SOURce]:RADIo:WCDMa:TGPP:ARB:LINK:DOWN:SETup: TABLE:CHANnel INIT APPend <chan_num>,<chan_type>, <symbol_rate>,<spread_code>,<power>,<tDPCH_offset>, <TFCI>,<TPC>,<scramble_code>,<scramble_type>, <scramble_offset>,<data_val>,<TFCI_power>, <TPC_power>,<pilot_power>,<pilot_bits> [:SOURce]:RADIo:WCDMa:TGPP:ARB:LINK:DOWN:SETup: TABLE:CHANnel? <chan_num> [:SOURce]:RADIo:WCDMa:TGPP:ARB:LINK:UP:SETup: TABLE:CHANnel INIT APPend <chan_num>,<chan_type>, <symbol_rate>,<spread_code>,<power>,<TFCI>,<TPC>, <data_val>,<fbi_bits_count>,<fbi_bits_value> [:SOURce]:RADIo:WCDMa:TGPP:ARB:LINK:UP:SETup: TABLE:CHANnel? <chan_num></pre> |
| Equal Energy per Symbol | <pre>[:SOURce]:RADIo:WCDMa:TGPP:ARB:LINK:DOWN:SETup: TABLE:PADJust EQUal</pre> |
| Ext | <pre>[:SOURce]:RADIo:WCDMa:TGPP:ARB:TRIGger[:SOURce] EXT [:SOURce]:RADIo:WCDMa:TGPP:ARB:TRIGger[:SOURce]?</pre> |
| Ext Delay Off On | <pre>[:SOURce]:RADIo:WCDMa:TGPP:ARB:TRIGger[:SOURce]: EXTernal:DELay:STATE ON OFF 1 0 [:SOURce]:RADIo:WCDMa:TGPP:ARB:TRIGger[:SOURce]: EXTernal:DELay:STATE?</pre> |

| Key | SCPI Command |
|----------------------------------|--|
| Ext Delay Time | [:SOURCE]:RADio:WCDMa:TGPP:ARB:TRIGger[:SOURCE]:EXTernal:DELaY <value> [:SOURCE]:RADio:WCDMa:TGPP:ARB:TRIGger[:SOURCE]:EXTernal:DELaY? |
| Ext Polarity Neg Pos | [:SOURCE]:RADio:WCDMa:TGPP:ARB:TRIGger[:SOURCE]:EXTernal:SLOPe POSitive NEGative [:SOURCE]:RADio:WCDMa:TGPP:ARB:TRIGger[:SOURCE]:EXTernal:SLOPe? |
| Filter Alpha | [:SOURCE]:RADio:WCDMa:TGPP:ARB:FILTer:ALPHa <value> [:SOURCE]:RADio:WCDMa:TGPP:ARB:FILTer:ALPHa? |
| Filter BbT | [:SOURCE]:RADio:WCDMa:TGPP:ARB:FILTer:BBT <value> [:SOURCE]:RADio:WCDMa:TGPP:ARB:FILTer:BBT? |
| First Spread Code | [:SOURCE]:RADio:WCDMa:TGPP:ARB:LINK:DOWN:SETup:TABLE:CHANnel INIT APPend <chan_num>,<chan_type>,<symbol_rate>,<spread_code>,<power>,<tDPCH_offset>,<TFCI>,<TPC>,<scramble_code>,<scramble_type>,<scramble_offset>,<data_val>,<TFCI_power>,<TPC_power>,<pilot_power>,<pilot_bits> [:SOURCE]:RADio:WCDMa:TGPP:ARB:LINK:DOWN:SETup:TABLE:CHANnel? <chan_num> |
| Gate Active | [:SOURCE]:RADio:WCDMa:TGPP:ARB:TRIGger:TYPE:GATE:ACTive LOW HIGH [:SOURCE]:RADio:WCDMa:TGPP:ARB:TRIGger:TYPE:GATE:ACTive? |
| Gated | [:SOURCE]:RADio:WCDMa:TGPP:ARB:TRIGger:TYPE GATE [:SOURCE]:RADio:WCDMa:TGPP:ARB:TRIGger:TYPE? |
| Gaussian | [:SOURCE]:RADio:WCDMa:TGPP:ARB:FILTer GAUSSian [:SOURCE]:RADio:WCDMa:TGPP:ARB:FILTer? |
| Insert DPDCH | [:SOURCE]:RADio:WCDMa:TGPP:ARB:LINK:UP:SETup:TABLE:CHANnel INIT APPend <chan_num>,<chan_type>,<symbol_rate>,<spread_code>,<power>,<TFCI>,<TPC>,<data_val>,<fbi_bits_count>,<fbi_bits_value> [:SOURCE]:RADio:WCDMa:TGPP:ARB:LINK:UP:SETup:TABLE:CHANnel? <chan_num> |
| I/Q Mapping Normal Invert | [:SOURCE]:RADio:WCDMa:TGPP:ARB:IQMap NORMAL INVert INVerted [:SOURCE]:RADio:WCDMa:TGPP:ARB:IQMap? |

| Key | SCPI Command |
|----------------------------------|--|
| IS-2000 SR3 DS | [:SOURCE]:RADIO:WCDMA:TGPP:ARB:FILTER IS2000SR3DS [:SOURCE]:RADIO:WCDMA:TGPP:ARB:FILTER? |
| IS-95 | [:SOURCE]:RADIO:WCDMA:TGPP:ARB:FILTER IS95 [:SOURCE]:RADIO:WCDMA:TGPP:ARB:FILTER? |
| IS-95 Mod | [:SOURCE]:RADIO:WCDMA:TGPP:ARB:FILTER IS95_MOD [:SOURCE]:RADIO:WCDMA:TGPP:ARB:FILTER? |
| IS-95 Mod w/EQ | [:SOURCE]:RADIO:WCDMA:TGPP:ARB:FILTER IS95_MOD_EQ [:SOURCE]:RADIO:WCDMA:TGPP:ARB:FILTER? |
| IS-95 w/EQ | [:SOURCE]:RADIO:WCDMA:TGPP:ARB:FILTER IS95_EQ [:SOURCE]:RADIO:WCDMA:TGPP:ARB:FILTER? |
| Left Alternate | [:SOURCE]:RADIO:WCDMA:TGPP:ARB:LINK:DOWN:SETup: TABLE:CHANnel INIT APPend <chan_num>,<chan_type>, <symbol_rate>,<spread_code>,<power>,<tDPCH_offset>, <TFCI>,<TPC>,<scramble_code>,<scramble_type>, <scramble_offset>,<data_val>,<TFCI_power>,<TPC_power>, <pilot_power>,<pilot_bits> [:SOURCE]:RADIO:WCDMA:TGPP:ARB:LINK:DOWN:SETup: TABLE:CHANnel? <chan_num> |
| Link Down Up | [:SOURCE]:RADIO:WCDMA:TGPP:ARB:LINK DOWN UP [:SOURCE]:RADIO:WCDMA:TGPP:ARB:LINK? |
| Modify All Scramble Codes | [:SOURCE]:RADIO:WCDMA:TGPP:ARB:LINK:DOWN:SETup: TABLE:CHANnel INIT APPend <chan_num>,<chan_type>, <symbol_rate>,<spread_code>,<power>,<tDPCH_offset>, <TFCI>,<TPC>,<scramble_code>,<scramble_type>, <scramble_offset>,<data_val>,<TFCI_power>,<TPC_power>, <pilot_power>,<pilot_bits> [:SOURCE]:RADIO:WCDMA:TGPP:ARB:LINK:DOWN:SETup: TABLE:CHANnel? <chan_num> |
| Multicarrier Define | [:SOURCE]:RADIO:WCDMA:TGPP:ARB:LINK:DOWN:SETup: MCArrier:TABLE INIT APPend <carrier_num>,DPCH1 DPCH3 PPSCH PPDPCH1 PPDPCH3 TM1D16 TM1D32 TM1D64 TM2 TM3D16 TM3D32 "<file name>",<freq_offset>,<power> [:SOURCE]:RADIO:WCDMA:TGPP:ARB:LINK:DOWN:SETup:MCArrier: TABLE? <carrier_num> [:SOURCE]:RADIO:WCDMA:TGPP:ARB:LINK:DOWN:SETup:MCArrier: TABLE:NCARriers? |
| Multicarrier Off On | [:SOURCE]:RADIO:WCDMA:TGPP:ARB:LINK:DOWN:SETup MCArrier [:SOURCE]:RADIO:WCDMA:TGPP:ARB:LINK:DOWN:SETup? |

| Key | SCPI Command |
|---------------------------------|--|
| Multiple Channels | <pre>[:SOURce]:RADio:WCDMa:TGPP:ARB:LINK:DOWN:SETup: TABLE:CHANnel INIT APPend <chan_num>,<chan_type>, <symbol_rate>,<spread_code>,<power>,<tDPCH_offset>, <TFCI>,<TPC>,<scramble_code>,<scramble_type>, <scramble_offset>,<data_val>,<TFCI_power>,<TPC_power>, <pilot_power>,<pilot_bits> [:SOURce]:RADio:WCDMa:TGPP:ARB:LINK:DOWN:SETup:TABLE: CHANnel? <chan_num></pre> |
| Nyquist | <pre>[:SOURce]:RADio:WCDMa:TGPP:ARB:FILTer NYQuist [:SOURce]:RADio:WCDMa:TGPP:ARB:FILTer?</pre> |
| Optimize FIR For EVM ACP | <pre>[:SOURce]:RADio:WCDMa:TGPP:ARB:FILTer:CHANnel EVM ACP [:SOURce]:RADio:WCDMa:TGPP:ARB:FILTer:CHANnel?</pre> |
| Oversample Ratio | <pre>:MEMory:DATA:FIR "<file name>",<osr>, coefficient{,<coefficient>} :MEMory:DATA:FIR? "<file name>"</pre> |
| PCCPCH | <pre>[:SOURce]:RADio:WCDMa:TGPP:ARB:LINK:DOWN:SETup: TABLE:CHANnel INIT APPend <chan_num>,<chan_type>, <symbol_rate>,<spread_code>,<power>,<tDPCH_offset>, <TFCI>,<TPC>,<scramble_code>,<scramble_type>, <scramble_offset>,<data_val>,<TFCI_power>,<TPC_power>, <pilot_power>,<pilot_bits> [:SOURce]:RADio:WCDMa:TGPP:ARB:LINK:DOWN:SETup: TABLE:CHANnel? <chan_num></pre> |
| PCCPCH + SCH | <pre>[:SOURce]:RADio:WCDMa:TGPP:ARB:LINK:DOWN:SETup PPSCH [:SOURce]:RADio:WCDMa:TGPP:ARB:LINK:DOWN:SETup?</pre> |
| PCCPCH + SCH + 1 DPCH | <pre>[:SOURce]:RADio:WCDMa:TGPP:ARB:LINK:DOWN:SETup PPDPCH1 [:SOURce]:RADio:WCDMa:TGPP:ARB:LINK:DOWN:SETup?</pre> |
| PCCPCH + SCH + 3 DPCH | <pre>[:SOURce]:RADio:WCDMa:TGPP:ARB:LINK:DOWN:SETup PPDPCH3 [:SOURce]:RADio:WCDMa:TGPP:ARB:LINK:DOWN:SETup?</pre> |
| PICH | <pre>[:SOURce]:RADio:WCDMa:TGPP:ARB:LINK:DOWN:SETup: TABLE:CHANnel INIT APPend <chan_num>,<chan_type>, <symbol_rate>,<spread_code>,<power>,<tDPCH_offset>, <TFCI>,<TPC>,<scramble_code>,<scramble_type>, <scramble_offset>,<data_val>,<TFCI_power>,<TPC_power>, <pilot_power>,<pilot_bits> [:SOURce]:RADio:WCDMa:TGPP:ARB:LINK:DOWN:SETup: TABLE:CHANnel? <chan_num></pre> |

| Key | SCPI Command |
|------------------------------|--|
| Power | <pre>[:SOURce]:RADio:WCDMa:TGPP:ARB:LINK:DOWN:SETup: TABLE:CHANnel INIT APPend <chan_num>,<chan_type>, <symbol_rate>,<spread_code>,<power>,<tDPCH_offset>, <TFCI>,<TPC>,<scramble_code>,<scramble_type>, <scramble_offset>,<data_VAL>,<TFCI_power>,<TPC_power>, <pilot_power>,<pilot_bits> [:SOURce]:RADio:WCDMa:TGPP:ARB:LINK:DOWN:SETup: TABLE:CHANnel? <chan_num> [:SOURce]:RADio:WCDMa:TGPP:ARB:LINK:UP:SETup: TABLE:CHANnel INIT APPend <chan_num>,<chan_type>, <symbol_rate>,<spread_code>,<power>,<TFCI>,<TPC>, <data_val>,<fbi_bits_count>,<fbi_bits_value> [:SOURce]:RADio:WCDMa:TGPP:ARB:LINK:UP:SETup: TABLE:CHANnel? <chan_num></pre> |
| PSCH | <pre>[:SOURce]:RADio:WCDMa:TGPP:ARB:LINK:DOWN:SETup: TABLE:CHANnel INIT APPend <chan_num>,<chan_type>, <symbol_rate>,<spread_code>,<power>,<tDPCH_offset>, <TFCI>,<TPC>,<scramble_code>,<scramble_type>, <scramble_offset>,<data_val>,<TFCI_power>,<TPC_power>, <pilot_power>,<pilot_bits> [:SOURce]:RADio:WCDMa:TGPP:ARB:LINK:DOWN:SETup: TABLE:CHANnel? <chan_num></pre> |
| Random | <pre>[:SOURce]:RADio:WCDMa:TGPP:ARB:LINK:DOWN:SETup: TABLE:CHANnel INIT APPend <chan_num>,<chan_type>, <symbol_rate>,<spread_code>,<power>,<tDPCH_offset>, <TFCI>,<TPC>,<scramble_code>,<scramble_type>, <scramble_offset>,<data_VAL>,<TFCI_power>,<TPC_power>, <pilot_power>,<pilot_bits> [:SOURce]:RADio:WCDMa:TGPP:ARB:LINK:DOWN:SETup: TABLE:CHANnel? <chan_num> [:SOURce]:RADio:WCDMa:TGPP:ARB:LINK:UP:SETup: TABLE:CHANnel INIT APPend <chan_num>,<chan_type>, <symbol_rate>,<spread_code>,<power>,<TFCI>,<TPC>, <data_val>,<fbi_bits_count>,<fbi_bits_value> [:SOURce]:RADio:WCDMa:TGPP:ARB:LINK:UP:SETup: TABLE:CHANnel? <chan_num></pre> |
| Reconstruction Filter | <pre>[:SOURce]:RADio:ARB:RFILter 250 kHz 2.5 MHz 8.0 MHz THROUGH [:SOURce]:RADio:ARB:RFILter?</pre> |
| Rectangle | <pre>[:SOURce]:RADio:WCDMa:TGPP:ARB:FILTer RECTangle [:SOURce]:RADio:WCDMa:TGPP:ARB:FILTer?</pre> |

| Key | SCPI Command |
|-------------------------------|---|
| Reference Frequency | [:SOURCE]:RADio:ARB:CLOCK:REFerence:EXTernal:FREQuency <value> [:SOURCE]:RADio:ARB:CLOCK:REFerence:EXTernal:FREQuency? |
| Restore Default Filter | [:SOURCE]:RADio:WCDMa:ARB:FILTer WCDMA [:SOURCE]:RADio:WCDMa:ARB:FILTer? |
| Retrigger Mode Off On | [:SOURCE]:RADio:WCDMa:TGPP:ARB:RETRigger ON OFF 1 0 [:SOURCE]:RADio:WCDMa:TGPP:ARB:RETRigger? |
| Right Alternate | [:SOURCE]:RADio:WCDMa:TGPP:ARB:LINK:DOWN:SETup:TABLE:CHANnel INIT APPend <chan_num>,<chan_type>,<symbol_rate>,<spread_code>,<power>,<tDPCH_offset>,<TFCI>,<TPC>,<scramble_code>,<scramble_type>,<scramble_offset>,<data_val>,<TFCI_power>,<TPC_power>,<pilot_power>,<pilot_bits> [:SOURCE]:RADio:WCDMa:TGPP:ARB:LINK:DOWN:SETup:TABLE:CHANnel? <chan_num> |
| Root Nyquist | [:SOURCE]:RADio:WCDMa:TGPP:ARB:FILTer RNYquist [:SOURCE]:RADio:WCDMa:TGPP:ARB:FILTer? |
| Scale To 0dB | [:SOURCE]:RADio:WCDMa:TGPP:ARB:LINK:DOWN:SETup:TABLE:PADJust SCALE |
| Scramble Code | [:SOURCE]:RADio:WCDMa:TGPP:ARB:LINK:DOWN:SETup:TABLE:CHANnel INIT APPend <chan_num>,<chan_type>,<symbol_rate>,<spread_code>,<power>,<tDPCH_offset>,<TFCI>,<TPC>,<scramble_code>,<scramble_type>,<scramble_offset>,<data_val>,<TFCI_power>,<TPC_power>,<pilot_power>,<pilot_bits> [:SOURCE]:RADio:WCDMa:TGPP:ARB:LINK:DOWN:SETup:TABLE:CHANnel? <chan_num> [:SOURCE]:RADio:WCDMa:TGPP:ARB:LINK:UP:SCRamble <value> [:SOURCE]:RADio:WCDMa:TGPP:ARB:LINK:UP:SCRamble? |
| Second DPDCH I Q | [:SOURCE]:RADio:WCDMa:TGPP:ARB:LINK:UP:SDPDch I Q [:SOURCE]:RADio:WCDMa:TGPP:ARB:LINK:UP:SDPDch? |
| Select | [:SOURCE]:RADio:WCDMa:TGPP:ARB:FILTer RNYquist NYquist GAUSSian RECTangle WCDMA IS95 IS95_EQ IS95_MOD IS95_MOD_EQ IS2000SR3DS AC4Fm UGGaussian "<file name>" [:SOURCE]:RADio:WCDMa:TGPP:ARB:FILTer? |

| Key | SCPI Command |
|----------------------------------|--|
| Select File | <pre>[:SOURce]:RADio:WCDMa:TGPP:ARB:FILTer "<file name>" [:SOURce]:RADio:WCDMa:TGPP:ARB:FILTer? [:SOURce]:RADio:WCDMa:TGPP:ARB:LINK:DOWN: SETup "<file name>" [:SOURce]:RADio:WCDMa:TGPP:ARB:LINK:DOWN:SETup? [:SOURce]:RADio:WCDMa:TGPP:ARB:LINK:UP: SETup "<file name>" [:SOURce]:RADio:WCDMa:TGPP:ARB:LINK:UP:SETup?</pre> |
| Single | <pre>[:SOURce]:RADio:WCDMa:TGPP:ARB:TRIGger:TYPE SINGLE [:SOURce]:RADio:WCDMa:TGPP:ARB:TRIGger:TYPE?</pre> |
| Spread Only | <pre>[:SOURce]:RADio:WCDMa:TGPP:ARB:LINK:DOWN:SETup: TABLE:CHANnel INIT APPend <chan_num>,<chan_type>,< symbol_rate>,<spread_code>,<power>,<tDPCH_offset>,< TFCI>,<TPC>,<scramble_code>,<scramble_type>,< scramble_offset>,<data_val>,<TFCI_power>,<TPC_power>,< pilot_power>,<pilot_bits> [:SOURce]:RADio:WCDMa:TGPP:ARB:LINK:DOWN:SETup: TABLE:CHANnel? <chan_num></pre> |
| Store Custom Multicarrier | <pre>[:SOURce]:RADio:WCDMa:TGPP:ARB:LINK:DOWN:SETup: MCArrier:STORE "<file name>"</pre> |
| Store Custom W-CDMA State | <pre>[:SOURce]:RADio:WCDMa:TGPP:ARB:LINK:DOWN:SETup: STORE "<file name>" [:SOURce]:RADio:WCDMa:TGPP:ARB:LINK:UP:SETup: STORE "<file name>"</pre> |
| Store to File | <pre>[:SOURce]:RADio:WCDMa:TGPP:ARB:LINK:DOWN:SETup: STORE "<file name>" [:SOURce]:RADio:WCDMa:TGPP:ARB:LINK:UP:SETup: STORE "<file name>"</pre> |

| Key | SCPI Command |
|--------------------------------|---|
| Symbol Rate | <pre>[:SOURce]:RADio:WCDMa:TGPP:ARB:LINK:DOWN:SETup: TABLE:CHANnel INIT APPend <chan_num>,<chan_type>, <symbol_rate>,<spread_code>,<power>,<tDPCH_offset>, <TFCI>,<TPC>,<scramble_code>,<scramble_type>, <scramble_offset>,<data_val>,<TFCI_power>,<TPC_power>, <pilot_power>,<pilot_bits> [:SOURce]:RADio:WCDMa:TGPP:ARB:LINK:DOWN:SETup: TABLE:CHANnel? <chan_num> [:SOURce]:RADio:WCDMa:TGPP:ARB:LINK:UP:SETup: TABLE:CHANnel INIT APPend <chan_num>,<chan_type>, <symbol_rate>,<spread_code>,<power>,<TFCI>,<TPC>, <data_val>,<fbi_bits_count>,<fbi_bits_value> [:SOURce]:RADio:WCDMa:TGPP:ARB:LINK:UP:SETup: TABLE:CHANnel? <chan_num></pre> |
| TFCI Field Off On | <pre>[:SOURce]:RADio:WCDMa:TGPP:ARB:LINK:DOWN: TFCI ON OFF 1 0 [:SOURce]:RADio:WCDMa:TGPP:ARB:LINK:DOWN:TFCI? [:SOURce]:RADio:WCDMa:TGPP:ARB:LINK:UP: TFCI ON OFF 1 0 [:SOURce]:RADio:WCDMa:TGPP:ARB:LINK:UP:TFCI?</pre> |
| Test Model 1 W/ 16 DPCH | <pre>[:SOURce]:RADio:WCDMa:TGPP:ARB:LINK:DOWN:SETup TM1D16 [:SOURce]:RADio:WCDMa:TGPP:ARB:LINK:DOWN:SETup?</pre> |
| Test Model 1 W/ 32 DPCH | <pre>[:SOURce]:RADio:WCDMa:TGPP:ARB:LINK:DOWN:SETup TM1D32 [:SOURce]:RADio:WCDMa:TGPP:ARB:LINK:DOWN:SETup?</pre> |
| Test Model 1 W/ 64 DPCH | <pre>[:SOURce]:RADio:WCDMa:TGPP:ARB:LINK:DOWN:SETup TM1D64 [:SOURce]:RADio:WCDMa:TGPP:ARB:LINK:DOWN:SETup?</pre> |
| Test Model 2 | <pre>[:SOURce]:RADio:WCDMa:TGPP:ARB:LINK:DOWN:SETup TM2 [:SOURce]:RADio:WCDMa:TGPP:ARB:LINK:DOWN:SETup?</pre> |
| Test Model 3 W/ 16 DPCH | <pre>[:SOURce]:RADio:WCDMa:TGPP:ARB:LINK:DOWN:SETup TM3D16 [:SOURce]:RADio:WCDMa:TGPP:ARB:LINK:DOWN:SETup?</pre> |
| Test Model 3 W/ 32 DPCH | <pre>[:SOURce]:RADio:WCDMa:TGPP:ARB:LINK:DOWN:SETup TM3D32 [:SOURce]:RADio:WCDMa:TGPP:ARB:LINK:DOWN:SETup?</pre> |
| Test Model 4 | <pre>[:SOURce]:RADio:WCDMa:TGPP:ARB:LINK:DOWN:SETup TM4 [:SOURce]:RADio:WCDMa:TGPP:ARB:LINK:DOWN:SETup?</pre> |
| Through | <pre>[:SOURce]:RADio:ARB:RFILter THROugh [:SOURce]:RADio:ARB:RFILter?</pre> |

| Key | SCPI Command |
|---------------------------|---|
| Trigger | [:SOURCE]:RADIO:WCDMA:TGPP:ARB:TRIGGER: TYPE CONTINUOUS SINGLE GATE [:SOURCE]:RADIO:WCDMA:TGPP:ARB:TRIGGER:TYPE? |
| Trigger Key | [:SOURCE]:RADIO:WCDMA:TGPP:ARB:TRIGGER[:SOURCE] KEY [:SOURCE]:RADIO:WCDMA:TGPP:ARB:TRIGGER[:SOURCE]? |
| Trigger Source | [:SOURCE]:RADIO:WCDMA:TGPP:ARB: TRIGGER[:SOURCE] KEY EXT BUS [:SOURCE]:RADIO:WCDMA:TGPP:ARB:TRIGGER[:SOURCE]? |
| Type | [:SOURCE]:RADIO:WCDMA:TGPP:ARB:LINK:DOWN:SETUP: TABLE:CHANNEL INIT APPEND <chan_num>, <chan_type>, <symbol_rate>, <spread_code>, <power>, <tDPCH_offset>, <TFCI>, <TPC>, <scramble_code>, <scramble_type>, <scramble_offset>, <data_val>, <TFCI_power>, <TPC_power>, <pilot_power>, <pilot_bits> [:SOURCE]:RADIO:WCDMA:TGPP:ARB:LINK:DOWN:SETUP: TABLE:CHANNEL? <chan_num> [:SOURCE]:RADIO:WCDMA:TGPP:ARB:LINK:UP:SETUP: TABLE:CHANNEL INIT APPEND <chan_num>, <chan_type>, <symbol_rate>, <spread_code>, <power>, <TFCI>, <TPC>, <data_val>, <fbi_bits_count>, <fbi_bits_value> [:SOURCE]:RADIO:WCDMA:TGPP:ARB:LINK:UP:SETUP: TABLE:CHANNEL? <chan_num> |
| UN3/4 GSM Gaussian | [:SOURCE]:RADIO:WCDMA:TGPP:ARB:FILTER UGGaussian [:SOURCE]:RADIO:WCDMA:TGPP:ARB:FILTER? |

| Key | SCPI Command |
|----------------------|--|
| WCDMA | <pre>[:SOURce]:RADio:WCDMa:TGPP:ARB:FILTer WCDMA [:SOURce]:RADio:WCDMa:TGPP:ARB:FILTer?</pre> |
| W-CDMA Off On | <pre>[:SOURce]:RADio:WCDMa:TGPP:ARB[:STATe] ON OFF 1 0 [:SOURce]:RADio:WCDMa:TGPP:ARB[:STATe]?</pre> |
| W-CDMA Select | <pre>[:SOURce]:RADio:WCDMa:TGPP:ARB:LINK:DOWN: SETup DPCH1 DPCH3 PPSCH PPDPCH1 PPDPCH3 TM1D16 TM1D32 TM1D64 TM2 TM3D16 TM3D32 TM4 MCARrier "<file name>" [:SOURce]:RADio:WCDMa:TGPP:ARB:LINK:DOWN:SETup? [:SOURce]:RADio:WCDMa:TGPP:ARB:LINK:UP:SETup DPCCH DDPDCH1 DDPDCH2 DDPDCH3 DDPDCH4 DDPDCH5 "<file name>" [:SOURce]:RADio:WCDMa:TGPP:ARB:LINK:UP:SETup? [:SOURce]:RADio:WCDMa:TGPP:ARB:LINK:DOWN:SETup: MCARrier CAR2 CAR3 CAR4 "<file name>" [:SOURce]:RADio:WCDMa:TGPP:ARB:LINK:DOWN:SETup: MCARrier?</pre> |

Numerics

- 1 DPCH softkey, [3-3](#)
- 120 ksps softkey, [3-3](#)
- 15 ksps softkey, [3-3](#)
- 2 Carriers softkey, [3-4](#)
- 2 softkey, [3-3](#)
- 2.500 MHz softkey, [3-4](#)
- 240 ksps softkey, [3-3](#)
- 250 kHz softkey, [3-6](#)
- 3 Carriers softkey, [3-4](#)
- 3 DPCH softkey, [3-4](#)
- 30 ksps softkey, [3-3](#)
- 3GPP specification, [1-2](#)
- 4 Carriers softkey, [3-5](#)
- 4 softkey, [3-5](#)
- 480 ksps softkey, [3-3](#)
- 60 ksps softkey, [3-3](#)
- 7.5 ksps softkey, [3-3](#)
- 8 softkey, [3-5](#)
- 8.000 MHz softkey, [3-5](#)
- 960 ksps softkey, [3-3](#)

A

- Adjust Code Domain Power softkey, [3-6](#)
- APCO 25 C4FM softkey, [3-6](#)
- Apply Channel Setup softkey, [3-6](#)
- Apply Multicarrier softkey, [3-6](#)
- Apply To Waveform softkey, [3-7](#)
- apply waveform SCPI command, [5-2](#)
- ARB Reference Ext Int softkey, [3-7](#)
- ARB reference source SCPI command, [5-2](#)
- ARIB 1.0-1.2 specification, [1-2](#)

B

- baseband clipping. *See* clipping
- Beta softkey, [3-7](#)
- bit rate, [4-5](#)
 - downlink, [4-4](#)
 - uplink, [4-5](#)
- bits per frame, [4-5](#)
 - downlink, [4-4](#)
 - uplink, [4-5](#)
- bits per slot, [4-5](#)
 - downlink, [4-4](#)
 - uplink, [4-5](#)
- block diagrams
 - downlink channel structure, [1-4](#)
 - DPDCH/DPCCH downlink frame structure, [4-4](#)

block diagrams (Continued)

- DPDCH/DPCCH uplink frame structure, [4-5](#)
- PCCPCH+SCH frame structure, [4-3](#)
- PICH frame structure, [4-2](#)
- uplink channel structure, [1-5](#)
- Bus softkey, [3-7](#)

C

- calculating downlink scramble codes, [4-16](#)
- carrier frequency, setting, [2-28](#)
- carrier power, setting, [2-28](#)
- catalogs
 - DWCDMA files, [2-20](#)
 - FIR files, [2-39](#)
 - MDWCDMA files, [2-25](#)
 - multicarrier W-CDMA files, [2-25](#)
 - uplink W-CDMA files, [2-20](#)
 - UWCDMA files, [2-20](#)
- channel configurations, editing downlink, [2-8](#)
- channel configurations, editing uplink, [2-14](#)
- channel setup SCPI command, [5-2](#)
- channels
 - DPCCH downlink, [4-4](#)
 - DPCCH uplink, [4-5](#)
 - DPDCH downlink, [4-4](#)
 - DPDCH uplink, [4-5](#)
 - editing values, [2-11](#), [2-17](#)
 - inserting DPCH, [2-8](#)
 - inserting DPDCH, [2-14](#), [2-15](#)
 - inserting PCCPCH, [2-9](#)
 - PCCPCH+SCH, [4-3](#)
 - PICH, [4-2](#)
- Channels softkey, [3-8](#)
- chip rate SCPI command, [5-5](#)
- Chip Rate softkey, [3-8](#)
- circular clipping, [4-12](#)
- Clip |I+jQ| To softkey, [3-8](#)
- Clip |I| To softkey, [3-9](#)
- Clip |Q| To softkey, [3-9](#)
- Clip At PRE POST FIR Filter softkey, [3-9](#)
- clipping
 - block diagram, downlink, [1-4](#)
 - block diagram, uplink, [1-5](#)
 - circular, [4-12](#)
 - concepts, [4-9](#)
 - FIR filtering options, [4-14](#)
 - intermodulation distortion, [4-11](#)
 - peak-to-average power, [4-12](#)
 - power peaks, [4-9](#)
 - rectangular, [4-12](#)

clipping (Continued)

- spectral regrowth, [4-11](#)
- using, [2-29](#)
- versus symbol offset, [4-15](#)
- clipping level, $|I+jQ|$ SCPI command, [5-5](#)
- clipping level, $|I|$ SCPI command, [5-5](#)
- clipping level, $|Q|$ SCPI command, [5-5](#)
- clipping pre/post FIR filter SCPI command, [5-5](#)
- Clipping softkey, [3-9](#)
- Clipping Type $|I+jQ|$ $|I|$, $|Q|$ softkeys, [3-10](#)
- clipping type SCPI command, [5-6](#)
- code domain
 - conflicts, identifying, [2-26](#)
 - conflicts, resolving, [2-26](#), [2-27](#)
- code domain power SCPI command, [5-6](#)
- coefficient values (FIR), entering, [2-32](#)
- concepts of operation, W-CDMA, [4-1](#)
- Continuous softkey, [3-10](#)
- CPICH softkey, [3-10](#)
- custom multicarrier W-CDMA waveforms
 - activating, [2-24](#)
 - creating, [2-22](#)
 - recalling, [2-25](#)
 - storing, [2-25](#)
- Custom W-CDMA Carrier softkey, [3-10](#)
- Custom W-CDMA Multicarrier softkey, [3-10](#)
- Custom W-CDMA State softkey, [3-11](#)

D

- data bits
 - downlink, [4-4](#)
 - uplink, [4-5](#)
- Define User FIR softkey, [3-11](#)
- Delete All Rows softkey, [3-11](#)
- Delete File softkey, [3-11](#)
- Delete Row softkey, [3-11](#)
- Display Code Domain Power softkey, [3-12](#)
- Display FFT softkey, [3-13](#)
- Display Impulse Response softkey, [3-14](#)
- downlink
 - bit rate, [4-4](#)
 - bits per frame, [4-4](#)
 - bits per slot, [4-4](#)
 - block diagram, [1-4](#)
 - channel configuration, editing, [2-8](#), [2-11](#)
 - channel configurations, selecting predefined, [2-5](#)
 - data bits, [4-4](#)
 - DPCCH fields, [4-4](#)
 - DPCCH frame structure, [4-4](#)

downlink (Continued)

- DPDCH fields, [4-4](#)
 - DPDCH frame structure, [4-4](#)
 - PCCPCH+SCH fields, [4-3](#)
 - PCCPCH+SCH frame structure, [4-3](#)
 - PICH frame structure, [4-2](#)
 - pilot bits, [4-4](#)
 - spread factor, [4-4](#)
 - symbol rate, [4-4](#)
 - TFCI bits, [4-4](#)
 - TPC bits, [4-4](#)
 - DPCCH
 - bits per frame, [4-4](#), [4-5](#)
 - bits per slot, [4-4](#), [4-5](#)
 - downlink channel fields, [4-4](#)
 - downlink frame structure, [4-4](#)
 - fields, [4-4](#), [4-5](#)
 - uplink channel fields, [4-5](#)
 - uplink frame structure, [4-5](#)
 - DPCCH + 1 DPDCH softkey, [3-14](#)
 - DPCCH + 2 DPDCH softkey, [3-14](#)
 - DPCCH + 3 DPDCH softkey, [3-15](#)
 - DPCCH + 4 DPDCH softkey, [3-15](#)
 - DPCCH + 5 DPDCH softkey, [3-15](#)
 - DPCCH softkey, [3-14](#)
 - DPCH
 - channels, inserting, [2-8](#)
 - DPCH softkey, [3-15](#)
 - DPDCH
 - bits per frame, [4-4](#), [4-5](#)
 - bits per slot, [4-4](#), [4-5](#)
 - channels
 - inserting, [2-14](#)
 - inserting additional, [2-15](#)
 - downlink channel fields, [4-4](#)
 - downlink frame structure, [4-4](#)
 - fields, [4-4](#), [4-5](#)
 - uplink channel fields, [4-5](#)
 - uplink frame structure, [4-5](#)
 - DWCDMA files
 - catalog, [2-20](#)
 - storing, [2-20](#)
- ## **E**
- Edit Channel Setup softkey, [3-15](#)
 - Edit Item softkey, [3-16](#)
 - Equal Energy per Symbol softkey, [3-16](#)
 - examples
 - channel configurations, editing
 - downlink, [2-8](#), [2-11](#)
 - uplink, [2-14](#), [2-17](#)

examples (Continued)

- channel configurations, selecting
 - overview, [2-4](#)
 - predefined downlink, [2-5](#)
 - predefined uplink, [2-6](#)
- coefficients, duplicating with mirror table, [2-33](#)
- FIR filter
 - creating, [2-31](#)
 - modifying, [2-36](#)
 - using, [2-39](#)
- W-CDMA softkey menu, accessing, [2-3](#)
- W-CDMA waveform, outputting, [2-28](#)
- Ext Delay Off On softkey, [3-16](#)
- Ext Delay Time softkey, [3-16](#)
- Ext Polarity Neg Pos softkey, [3-17](#)
- Ext softkey, [3-16](#)
- external trigger delay state SCPI command, [5-6](#)
- external trigger delay time SCPI command, [5-6](#)
- external trigger polarity SCPI command, [5-7](#)

F

- FBI bits, [4-5](#)
- features, [1-3](#)
- files
 - custom multicarrier W-CDMA waveform
 - recalling, [2-25](#)
 - storing, [2-25](#)
 - downlink W-CDMA catalog, [2-20](#)
 - FIR files catalog, [2-39](#)
 - loading FIR, [2-36](#)
 - multicarrier W-CDMA catalog, [2-25](#)
 - storing FIR filter, [2-35](#), [2-38](#)
 - uplink W-CDMA catalog, [2-20](#)
- filter
 - FIR filter
 - block diagram, downlink, [1-4](#)
 - block diagram, uplink, [1-5](#)
 - clipping options, [4-14](#)
 - creating windowed sinc function, [2-31](#)
 - modifying, [2-36](#)
 - user-defined, [2-31](#)
 - using a custom filter, [2-39](#)
 - windowed sinc function, creating, [2-31](#)
 - FIR table editor
 - accessing, [2-31](#)
 - coefficients, duplicating with mirror table, [2-33](#)
 - creating user-defined filter, [2-31](#)
 - creating windowed sinc function, [2-31](#)
 - entering coefficient values, [2-32](#)
 - loading files, [2-36](#)
 - modifying coefficients, [2-37](#)
 - modifying FIR filter, [2-36](#)
 - setting oversample ratio, [2-33](#), [5-13](#)
 - storing filter, [2-35](#), [2-38](#)

- filter alpha SCPI command, [5-7](#)
- Filter Alpha softkey, [3-17](#)
- filter BbT SCPI command, [5-7](#)
- Filter BbT softkey, [3-18](#)
- Filter Factor softkey, [3-18](#)
- filter optimization SCPI command, [5-7](#)
- filter selection SCPI command, [5-8](#)
- Filter softkey, [3-17](#)
- Filter Symbols softkey, [3-19](#)
- First Spread Code softkey, [3-19](#)
- frame structure
 - downlink
 - DPCCH, [4-4](#)
 - DPDCH, [4-4](#)
 - PCCPCH+SCH, [4-3](#)
 - PICH, [4-2](#)
 - uplink
 - DPCCH, [4-5](#)
 - DPDCH, [4-5](#)
- frequency
 - setting, [2-28](#)

G

- Gain Unit dB Lin Index softkey, [3-20](#)
- gain unit SCPI command, [5-8](#)
- gate active SCPI command, [5-9](#)
- Gate Active softkey, [3-20](#)
- Gated softkey, [3-20](#)
- Gaussian softkey, [3-20](#)
- Goto Bottom Row softkey, [3-21](#)
- Goto Middle Row softkey, [3-21](#)
- Goto Row softkey, [3-21](#)
- Goto Top Row softkey, [3-21](#)
- guides
 - two-volume set, [1-2](#)
 - W-CDMA (3GPP 3.4 12-00), [1-2](#)
 - W-CDMA (ARIB 1.0-1.2), [1-2](#)

H

- Hamming softkey, [3-21](#)
- Hann softkey, [3-22](#)
- hardkey, Mode, [3-2](#)

I

- I/Q Mapping Normal Invert softkey, [3-22](#)
- I/Q mapping SCPI command, [5-9](#)
- Insert DPDCH softkey, [3-22](#)
- Insert Row softkey, [3-22](#)
- intermodulation distortion, [4-9](#), [4-11](#)

IS-2000 SR3 DS softkey, [3-23](#)
IS-95 and IS-2000 softkey, [3-23](#)
IS-95 Mod softkey, [3-23](#)
IS-95 Mod w/EQ softkey, [3-23](#)
IS-95 softkey, [3-23](#)
IS-95 w/EQ softkey, [3-23](#)

K

Kaiser softkey, [3-24](#)
key descriptions, [3-1](#)

L

left alternate scramble type, [4-16](#)
Left Alternate softkey, [3-24](#)
link direction SCPI command, [5-9](#)
Link Down Up softkey, [3-24](#)
Load Default FIR softkey, [3-24](#)
Load From Selected File softkey, [3-25](#)
Load/Store softkey, [3-25](#)

M

manuals
 two-volume set, [1-2](#)
 W-CDMA (3GPP 3.4 12-00), [1-2](#)
 W-CDMA (ARIB 1.0-1.2), [1-2](#)
MDWCDMA files
 catalog, [2-25](#)
 storing, [2-25](#)
memory
 DWCDMA files, [2-20](#)
 MDWCDMA files, [2-25](#)
 storing a W-CDMA state, [2-20](#)
 UWCDMA files, [2-20](#)
Mirror Table softkey, [3-25](#)
mirror table, duplicating coefficients, [2-33](#)
mode - W-CDMA softkeys, [6-2](#)
Mode hardkey, [3-2](#)
Modify All Scramble Codes softkey, [3-25](#)
multicarrier define SCPI command, [5-9](#)
Multicarrier Define softkey, [3-25](#)
Multicarrier Off On softkey, [3-26](#)
multicarrier setup select SCPI command, [5-10](#)
multicarrier W-CDMA
 activating waveforms, [2-24](#)
 creating custom waveforms, [2-22](#)
 editing template, [2-23](#)
 files catalog, [2-25](#)
 recalling waveforms, [2-25](#)
 storing waveforms, [2-25](#)

multicarrier, store custom SCPI command, [5-11](#)
Multiple Channels softkey, [3-26](#)

N

n ksps softkey, [3-3](#)
Next Scramble Code softkey, [3-26](#)
None softkey, [3-26](#)
Nyquist softkey, [3-27](#)

O

OCNS softkey, [3-27](#)
operation concepts, W-CDMA, [4-1](#)
Optimize FIR For EVM ACP softkey, [3-27](#)
Oversample Ratio softkey, [3-28](#)
overview
 block diagrams, [1-3](#)
 Option 100 features, [1-3](#)
 revision numbers, [1-3](#)
 specifications, [1-3](#)
 W-CDMA personality, [1-3](#)

P

Page Down softkey, [3-28](#)
Page Up softkey, [3-28](#)
PCCPCH + SCH + 1 DPCH softkey, [3-28](#)
PCCPCH + SCH + 3 DPCH softkey, [3-29](#)
PCCPCH + SCH softkey, [3-28](#)
PCCPCH channel
 inserting, [2-9](#)
PCCPCH softkey, [3-28](#)
PCCPCH+SCH
 fields, [4-3](#)
 frame structure, [4-3](#)
peak-to-average power, [4-12](#)
personality overview, [1-3](#)
PICH
 frame structure, [4-2](#)
PICH softkey, [3-29](#)
pilot bits
 downlink, [4-4](#)
 uplink, [4-5](#)
pilot power, [4-7](#)
Plot CCDF softkey, [3-29](#)
PN9 softkey, [3-29](#)
power
 clipping peaks, [4-9](#)
 offsets
 pilot, [4-7](#)
 TFCI, [4-7](#)

power offsets (Continued)

- TPC, 4-7
- setting, 2-28
- Power softkey, 3-30
- predefined channel configurations, 2-4
 - downlink, 2-5
 - uplink, 2-6
- Previous Scramble Code softkey, 3-30
- Primary Key softkey, 3-30
- primary scramble codes, 4-16
- programming command cross-reference, 6-1
- PSCH softkey, 3-30

R

- Random softkey, 3-31
- Rate softkey, 3-31
- reconstruction filter SCPI command, 5-11
- Reconstruction Filter softkey, 3-31
- Rectangle softkey, 3-31
- rectangular clipping, 4-12
- reference frequency SCPI command, 5-11
- Reference Frequency softkey, 3-32
- Reset Table softkey, 3-32
- Restore Default Filter softkey, 3-32
- Retrigger Mode Off On softkey, 3-32
- retrigger mode state SCPI command, 5-11
- revision numbers, 1-3
- right alternate scramble type, 4-16
- Right Alternate softkey, 3-32
- Root Nyquist softkey, 3-33

S

- Scale To 0dB softkey, 3-33
- SCCPCH softkey, 3-33
- SCPI commands
 - apply waveform, 5-2
 - ARB reference source, 5-2
 - channel setup, 5-2
 - chip rate, 5-5
 - clipping level, $|I+jQ|$, 5-5
 - clipping level, $|I|$, 5-5
 - clipping level, $|Q|$, 5-5
 - clipping pre/post FIR filter, 5-5
 - clipping type, 5-6
 - code domain power, 5-6
 - external trigger delay state, 5-6
 - external trigger delay time, 5-6
 - external trigger polarity, 5-7
 - filter alpha, 5-7

SCPI commands (Continued)

- filter BbT, 5-7
- filter optimization, 5-7
- filter selection, 5-8
- gain unit, 5-8
- gate active, 5-9
- I/Q mapping, 5-9
- link direction, 5-9
- multicarrier define, 5-9
- multicarrier setup select, 5-10
- multicarrier, store custom, 5-11
- reconstruction filter, 5-11
- reference frequency, 5-11
- retrigger mode state, 5-11
- scramble code, 5-12
- second DPDCH setup, 5-12
- TFCI field state, 5-12
- trigger source, 5-12
- trigger type, 5-13
- user FIR definition, 5-13
- W-CDMA link setup, 5-13
- W-CDMA state, 5-14
- W-CDMA, store custom, 5-15
- SCPI commands, cross-reference, 6-1
- SCPI commands, descriptions, 5-1
- scramble code
 - calculating, 4-16
 - primary, 4-16
 - scramble offset, 4-16
 - scramble type, 4-16
 - secondary, 4-16
- scramble code SCPI command, 5-12
- Scramble Code softkey, 3-34
- scramble offset, 4-16
- Scramble Offset softkey, 3-35
- Scramble softkey, 3-34
- scramble type, 4-16
 - left alternate, 4-16
 - right alternate, 4-16
 - standard, 4-16
- Scramble Type softkey, 3-35
- Second DPDCH I Q softkey, 3-36
- second DPDCH setup SCPI command, 5-12
- Secondary Key softkey, 3-36
- Select File softkey, 3-37
- sinc function, windowed, creating a filter, 2-31
- Single softkey, 3-37
- softkeys
 - 1 DPCH, 3-3
 - 2, 3-3
 - 2 Carriers, 3-4

softkeys (Continued)

2.500 MHz, 3-4
250 kHz, 3-6
3 Carriers, 3-4
3 DPCH, 3-4
4, 3-5
4 Carriers, 3-5
8, 3-5
8.000 MHz, 3-5
Adjust Code Domain Power, 3-6
APCO 25 C4FM, 3-6
Apply Channel Setup, 3-6
Apply Multicarrier, 3-6
Apply To Waveform, 3-7
ARB Reference Ext Int, 3-7
Beta, 3-7
Bus, 3-7
Channels, 3-8
Chip Rate, 3-8
Clip $|I+jQ|$ To, 3-8
Clip $|I|$ To, 3-9
Clip $|Q|$ To, 3-9
Clip At PRE POST FIR Filter, 3-9
Clipping, 3-9
Clipping Type $|I+jQ|$ $|I|$, $|Q|$, 3-10
Continuous, 3-10
CPICH, 3-10
Custom W-CDMA Carrier, 3-10
Custom W-CDMA Multicarrier, 3-10
Custom W-CDMA State, 3-11
Define User FIR, 3-11
Delete All Rows, 3-11
Delete File, 3-11
Delete Row, 3-11
descriptions, 3-1
Display Code Domain Power, 3-12
Display FFT, 3-13
Display Impulse Response, 3-14
DPCCH, 3-14
DPCCH + 1 DPDCH, 3-14
DPCCH + 2 DPDCH, 3-14
DPCCH + 3 DPDCH, 3-15
DPCCH + 4 DPDCH, 3-15
DPCCH + 5 DPDCH, 3-15
DPCH, 3-15
Edit Channel Setup, 3-15
Edit Item, 3-16
Equal Energy per Symbol, 3-16
Ext, 3-16
Ext Delay Off On, 3-16
Ext Delay Time, 3-16
Ext Polarity Neg Pos, 3-17

softkeys (Continued)

Filter, 3-17
Filter Alpha, 3-17
Filter BbT, 3-18
Filter Factor, 3-18
Filter Symbols, 3-19
First Spread Code, 3-19
Gain Unit dB Lin Index, 3-20
Gate Active, 3-20
Gated, 3-20
Gaussian, 3-20
Goto Bottom Row, 3-21
Goto Middle Row, 3-21
Goto Row, 3-21
Goto Top Row, 3-21
Hamming, 3-21
Hann, 3-22
I/Q Mapping Normal Invert, 3-22
Insert DPDCH, 3-22
Insert Row, 3-22
IS-2000 SR3 DS, 3-23
IS-95, 3-23
IS-95 and IS-2000, 3-23
IS-95 Mod, 3-23
IS-95 Mod w/EQ, 3-23
IS-95 w/EQ, 3-23
Kaiser, 3-24
Left Alternate, 3-24
Link Down Up, 3-24
Load Default FIR, 3-24
Load From Selected File, 3-25
Load/Store, 3-25
Mirror Table, 3-25
Modify All Scramble Codes, 3-25
Multiple Channels, 3-26
n ksps, 3-3
Next Scramble Code, 3-26
None, 3-26
Nyquist, 3-27
OCNS, 3-27
Optimize FIR For EVM ACP, 3-27
Oversample Ratio, 3-28
Page Down, 3-28
Page Up, 3-28
PCCPCH, 3-28
PCCPCH + SCH, 3-28
PCCPCH + SCH + 1 DPCH, 3-28
PCCPCH + SCH + 3 DPCH, 3-29
PICH, 3-29
Plot CCDF, 3-29
PN9, 3-29
Power, 3-30

softkeys (Continued)

- Previous Scramble Code, [3-30](#)
- Primary Key, [3-30](#)
- PSCH, [3-30](#)
- Random, [3-31](#)
- Rate, [3-31](#)
- Reconstruction Filter, [3-31](#)
- Rectangle, [3-31](#)
- Reference Frequency, [3-32](#)
- Reset Table, [3-32](#)
- Restore Default Filter, [3-32](#)
- Retrigger Mode Off On, [3-32](#)
- Right Alternate, [3-32](#)
- Root Nyquist, [3-33](#)
- Scale To 0dB, [3-33](#)
- SCCPCH, [3-33](#)
- Scramble, [3-34](#)
- Scramble Code, [3-34](#)
- Scramble Offset, [3-35](#)
- Scramble Type, [3-35](#)
- Second DPDCH I Q, [3-36](#)
- Secondary Key, [3-36](#)
- Select File, [3-37](#)
- Single, [3-37](#)
- Sort, [3-37](#)
- Sort Table, [3-37](#)
- Spread Code, [3-37](#)
- SSCH, [3-37](#)
- Standard, [3-38](#)
- Store Custom Multicarrier, [3-38](#)
- Store Custom W-CDMA State, [3-38](#)
- Store To File, [3-39](#)
- Symbol Rate, [3-39](#)
- Test Model 1 W/ 16 DPCH, [3-40](#)
- Test Model 1 W/ 32 DPCH, [3-40](#)
- Test Model 1 W/ 64 DPCH, [3-40](#)
- Test Model 2 softkey, [3-41](#)
- Test Model 3 W/ 16 DPCH, [3-41](#)
- Test Model 3 W/ 32 DPCH, [3-41](#)
- Test Model 4, [3-41](#)
- Test Models, [3-40](#)
- TFCI Field Off On, [3-42](#)
- Through, [3-42](#)
- Trigger, [3-42](#)
- Trigger Key, [3-42](#)
- Trigger Setup, [3-42](#)
- Trigger Source, [3-43](#)
- Type, [3-43](#)
- UN3/4 GSM Gaussian, [3-43](#)
- User FIR, [3-43](#)
- View Next Page, [3-44](#)
- Waveform Statistics, [3-44](#)

softkeys (Continued)

- WCDMA, [3-44](#)
- W-CDMA (3GPP 3.4 12-00), [3-44](#)
- W-CDMA Define, [3-44](#)
- W-CDMA Off On, [3-45](#)
- W-CDMA Select, [3-45](#)
- Window, [3-46](#)
- See also individual softkeys
- softkeys Multicarrier Define, [3-25](#)
- softkeys Multicarrier Off On, [3-26](#)
- Sort softkey, [3-37](#)
- Sort Table softkey, [3-37](#)
- specification
 - 3GPP, [1-2](#)
 - ARIB 1.0-1.2, [1-2](#)
- specifications, [1-3](#)
- spectral regrowth, [4-9](#), [4-11](#)
- Spread Code softkey, [3-37](#)
- spread factor
 - downlink, [4-4](#)
 - uplink, [4-5](#)
- SSCH softkey, [3-37](#)
- standard scramble type, [4-16](#)
- Standard softkey, [3-38](#)
- Store Custom Multicarrier softkey, [3-38](#)
- Store Custom W-CDMA State softkey, [3-38](#)
- Store To File softkey, [3-39](#)
- symbol
 - offset versus clipping, [4-15](#)
- symbol rate
 - downlink, [4-4](#)
 - uplink, [4-5](#)
- Symbol Rate softkey, [3-39](#)

T

- table editors
 - channel setup
 - downlink, [2-8](#), [2-11](#)
 - uplink, [2-14](#), [2-17](#)
 - editing basics, [2-2](#)
- Test Model 1 W/ 16 DPCH softkey, [3-40](#)
- Test Model 1 W/ 32 DPCH softkey, [3-40](#)
- Test Model 1 W/ 64 DPCH softkey, [3-40](#)
- Test Model 2 softkey, [3-41](#)
- Test Model 3 W/ 16 DPCH softkey, [3-41](#)
- Test Model 3 W/ 32 DPCH softkey, [3-41](#)
- Test Model 4 softkey, [3-41](#)
- Test Models softkey, [3-40](#)
- TFC field state SCPI command, [5-12](#)

- TFCI
 - power, [4-7](#)
 - TFCI bits
 - downlink, [4-4](#)
 - uplink, [4-5](#)
 - TFCI Field Off On softkey, [3-42](#)
 - theory of operation, W-CDMA, [4-1](#)
 - Through softkey, [3-42](#)
 - TPC bits
 - downlink, [4-4](#)
 - uplink, [4-5](#)
 - TPC power, [4-7](#)
 - TPC values, [4-6](#)
 - transmit power control, [4-6](#)
 - Trigger Key softkey, [3-42](#)
 - Trigger Setup softkey, [3-42](#)
 - Trigger softkey, [3-42](#)
 - trigger source SCPI command, [5-12](#)
 - Trigger Source softkey, [3-43](#)
 - trigger type SCPI command, [5-13](#)
 - Type softkey, [3-43](#)
- U**
- UN3/4 GSM Gaussian softkey, [3-43](#)
 - uplink
 - bit rate, [4-5](#)
 - bits per frame, [4-5](#)
 - bits per slot, [4-5](#)
 - block diagram, [1-5](#)
 - channel setup, editing, [2-14](#), [2-17](#)
 - data bits, [4-5](#)
 - DPCCCH fields, [4-5](#)
 - DPCCCH frame structure, [4-5](#)
 - DPDCH fields, [4-5](#)
 - DPDCH frame structure, [4-5](#)
 - editing channel configurations, [2-14](#)
 - FBI bits, [4-5](#)
 - pilot bits, [4-5](#)
 - predefined channel configurations, [2-6](#)
 - spread factor, [4-5](#)
 - symbol rate, [4-5](#)
 - TFC bits, [4-5](#)
 - TFCI bits, [4-5](#)
 - user files
 - FIR files catalog, [2-39](#)
 - user FIR definition SCPI command, [5-13](#)
 - User FIR softkey, [3-43](#)
 - user's and programming guide
 - two-volume set, [1-2](#)
 - user's and programming guides
 - W-CDMA (3GPP 3.4 12-00), [1-2](#)
 - W-CDMA (ARIB 1.0-1.2), [1-2](#)
 - UWCDMA files
 - catalog, [2-20](#)
 - storing, [2-20](#)
- V**
- View Next Page softkey, [3-44](#)
- W**
- Waveform Statistics softkey, [3-44](#)
 - W-CDMA
 - 3GPP specification, [1-2](#)
 - ARIB specification, [1-2](#)
 - channel configurations, [2-5](#)
 - channel configurations, editing
 - downlink, [2-8](#)
 - uplink, [2-14](#)
 - channel configurations, predefined
 - overview, [2-4](#)
 - uplink, [2-6](#)
 - multicarrier template, editing, [2-23](#)
 - personality, [1-3](#)
 - RF output, enabling, [2-29](#)
 - softkey menu, accessing, [2-3](#)
 - theory of operation, [4-1](#)
 - using, [2-3](#)
 - waveforms
 - clipping, [2-29](#)
 - generating, [2-29](#)
 - outputting, [2-28](#)
 - storing, [2-20](#)
 - W-CDMA (3GPP 3.4 12-00) softkey, [3-44](#)
 - W-CDMA Define softkey, [3-44](#)
 - W-CDMA link setup SCPI command, [5-13](#)
 - W-CDMA Off On softkey, [3-45](#)
 - W-CDMA Select softkey, [3-45](#)
 - WCDMA softkey, [3-44](#)
 - W-CDMA state SCPI command, [5-14](#)
 - W-CDMA, store custom SCPI command, [5-15](#)
 - Window softkey, [3-46](#)
-